

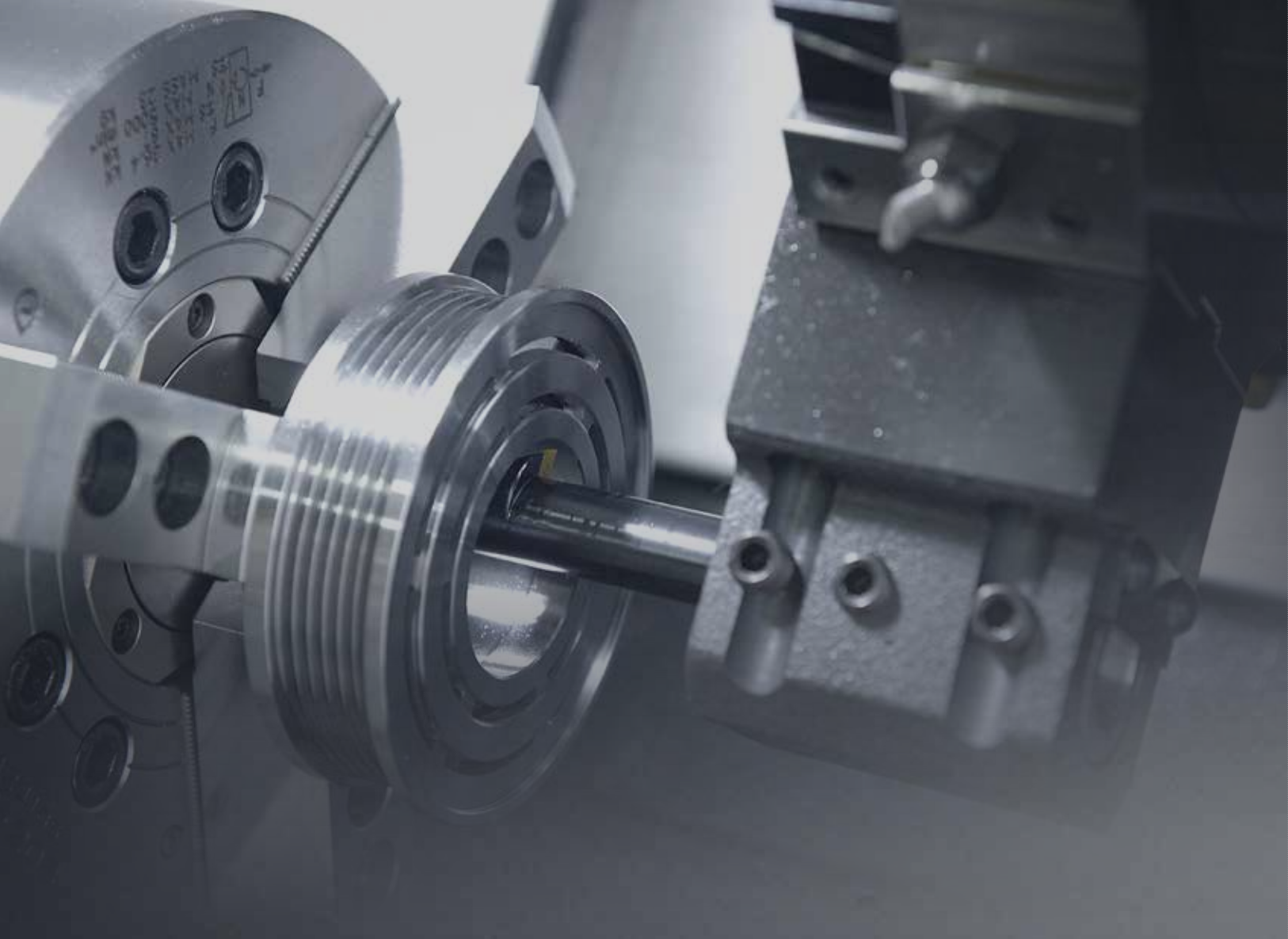

160 Series

E160A | E160C

HYUNDAI WIA Efficient Type CNC Turning Center



Technical Leader

The CNC Turning Center E160 Series, designed by Hyundai WIA with years of expertise and the latest technology, maximizes productivity by enhancing both technical performance and economic efficiency.

		E160A	E160C
Max. Turning Dia.	mm(in)	Ø280 (Ø11")	Ø280 (Ø11")
Max. Turning Length	mm(in)	300 (11.8")	280 (11")
Chuck Size	inch	6"	8"
Bar Capacity	mm(in)	Ø45 (Ø1.8")	Ø51 (Ø2")
Sp. Speed	r/min	6,000 [6,000]	4,000 [4,000] [4,000]
Sp. Motor (Max./Cont.)	kW(HP)	11/7.5 (15/10) [10.8/9 (14.5/12)]	11/7.5 (15/10) [15/11 (20/15)] [10.8/9 (14.5/12)]
Travel (X/Z)	mm(in)	165/330 (6.5"/13")	165/330 (6.5"/13")
No. of Tools	EA	12	10

[] : Option

E

160 Series

High Speed, Rigidity & Productivity-CNC Turning Center

- 45° slanted one-piece bed structure with high rigidity
- Stabilized unit structure to minimize thermal displacement
- Impressive rapid traverse rate: 30m/min
- The most reliable high speed servo turret : 0.1sec/step
- Environmental friendly design
- Compact design suitable for installation in restricted space
- Ergonomic design for convenient access to chuck and tool



01 BASIC STRUCTURE

The Best Productivity 6 inch / 8 inch Compact CNC Turning Center

High Precision Spindle

- Angular bearing : P4
- E160A : 6" / 6,000 r/min
- E160C : 8" / 4,000 r/min

Turret

- Indexing Time : 0.1 sec
- Tool Size (O.D./I.D.)
E160A : $\square 20/\emptyset 32$ ($\square 0.8"/\emptyset 1.2"$)
E160C : $\square 25/\emptyset 32$ ($\square 1"/\emptyset 1.2"$)

OPTION

Tail Stock

- Taper : MT #4
- Quill Travel : 80 mm (3.1")



REDUCTION OF NON-CUTTING TIME BY FAST RAPID SPEED

ALL-IN-ONE TYPE OF BED

High Precision & Rigidity One-piece Structure

The E160 Series is designed with a 45 degree slanted bed combined with square type and tube type rib structure. This special design enhances rigidity and vibration absorbing capability, allowing powerful cutting with high precision.

Floor Space (L×W)

1,940×1,660 mm (76.4"×65.4")

45° Bed Slant

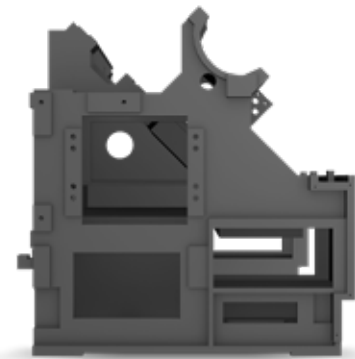

GUIDEWAY

LM Guideway

LM guideway with the rapid traverse rate of 30 m/min (1,181ipm) is installed on E160 Series.

LM guideway maintains high precision even after a long periods of operation. LM guideway's wide surface minimizes attrition and slipping which can occur often during machining.

Ball Screw

In order to eliminate thermal growth and increase accuracy, all axis are driven by high precision double anchored ballscrews.

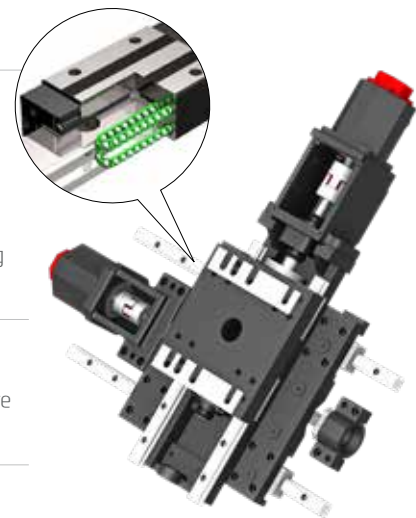

Travel (X/Z)

165/330 mm (6.5"/13")

Rapid Traverse Rate (X/Z)

30/30 m/min (1,181/1,181 ipm)

02 HIGH PRECISION

Excellent Performance, High Accuracy Cutting CNC Turning Center

Spindle Specifications

[] : Option

ITEM	Spindle Speed	Motor (Max./Cont.)	Torque (Max.)	Driving Method
E160A	FANUC : 6,000 r/min	11/7.5 kW (15/10 HP)	70/35.8 N·m (51.6/26.4 lbf·ft)	Belt
	[ITROL : 6,000 r/min]	10.8/9 kW (14.5/12 HP)	75.6/68.7 N·m (55.8/50.7 lbf·ft)	
E160C	FANUC : 4,000 r/min	11/7.5 kW (15/10 HP)	126/64.4 N·m (92.9/47.5 lbf·ft)	
	[FANUC : 4,000 r/min]	15/11 kW (20/15 HP)	171.8/126 N·m (126.7/92.9 lbf·ft)	
	[ITROL : 4,000 r/min]	10.8/9 kW (14.5/12 HP)	136/113.4 N·m (100.3/83.6 lbf·ft)	

High-Precision

HIGH ACCURACY & EXCELLENT PERFORMANCE

SPINDLE

High Precision Spindle

The E160 Series spindle was designed with a precise and highly rigid spindle structure by adopting a high speed angular ball bearing in the DB array.

To ensure good safety in the powerful and heavy cutting, the spindle is designed with an angular bearing structure with P4 class.



TURRET

Servo Turret

Continued accuracy of the turret indexing position is maintained by a powerful, high speed servo motor. The 3 piece coupling and non-lift method applied design prevents foreign material from getting into the turret.

Turret Specifications

ITEM	No. of Tools	Tool Size (O.D/I.D)	Indexing Time
E160A	12 EA	□ 20/Ø32 mm (□ 0.8"/Ø1.2")	0.1 sec
E160C	10 EA	□ 25/Ø32 mm (□ 1"/Ø1.2")	

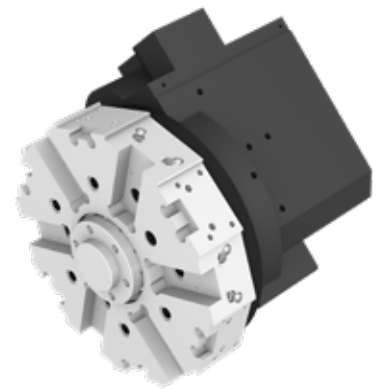

TAIL STOCK

MT#4 Tail Stock

Tailstock enables stable machining of high quality products where quill travels up to 80mm (3").

- ◎ Quill Dia. : Ø55 mm (Ø2.2")
- ◎ Quill Travel : 80 mm (3.1")

OPTION

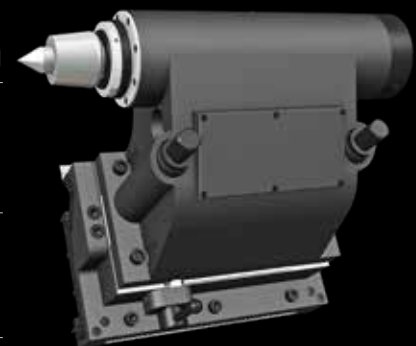

03 HYUNDAI WIA FANUC – SMART PLUS

The Compatible All-round Control



15" Touch-type Monitor as a standard

	Fast Cycle Time Technology
Smart Machine Control	Fine Surface Technology
	Smart Servo Control Technology
Conversational Program	SmartGuide-i
i-HMI	Machining-aid Function
Part Program Storage	5120M (2MB)
No. of Registerable Programs	1000 EA



SMART SOFTWARE



Dialogue Program (Smart Guide-i)

This software offers the maximum user convenience through dialogue manipulation from setup to processing. This includes writing processing programs and simulation checks.

Convenience Function S/W



1. Thermal Displacement Compensation (HW-TDC) OPTION
This software improves processing precision by minimizing thermal deformation from changes in external environments and machining.

2. Machine Guidance (HW-MCG)
This software offers various user convenience functions such as tool manipulation, maintenance, tool monitoring, and a pop-up/status

3. LAUNCHER
This software offers shortcuts for quick access to specialized features and frequently used features.

4. Tool Monitoring (HW-TM) OPTION
This tool status monitoring software monitors and protects workpiece, tools, and equipment through real-time monitoring of the motor load from machining.

Machining Support S/W

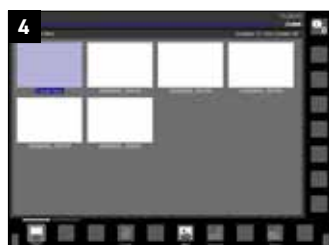

1. Premium Tool Operation
This software offers premium graphic functions for more intuitive tool operation. (Only in iHMI tools)

2. Manual Viewer
This software enables users to view electronic manuals right from the tool. (Only in iHMI tools)

3. Scheduling
This software enables viewing/setting up directly from the tool. This allows such actions as managing customer's tool schedules and schedule notification. (Only in iHMI tools)

4. Operation Memo
This software is capable of managing customer notes such as tool information and issues. (Only in iHMI tools)

SPECIFICATIONS

Standard & Optional

● : Standard ○ : Option ☆ : Prior Consultation - : Non Applicable

Spindle		E160A	E160C
Main Spindle	6"	●	-
Hollow Chuck 3 Jaw	8"	○	●
Main Spindle	6"	○	-
Solid Chuck 3 Jaw	8"	-	○
Standard Soft Jaw (1set)		●	●
Chuck Clamp Foot Switch		●	●
2 Steps Hyd. Pressure Device		○	○
Spindle Inside Stopper		☆	☆
5" Index		☆	☆
C-Axis (0.001")		-	-
Chuck Open/Close Confirmation Device		○	○
2 Steps Chuck Foot Switch		☆	☆
Turret			
Tool Holder		●	●
Mill Turret	VDI	-	-
Straight Milling Head (Axial)	Collet Type, 1ea	-	-
Angular Milling Head (Radial)	Collet Type, 1ea	-	-
Straight Milling Head (Axial)	Adapter Type	-	-
Angular Milling Head (Radial)	Adapter Type	-	-
Boring Sleeve		●	●
Drill Socket		●	●
U-Drill Holder		○	○
U-Drill Holder Sleeve		○	○
O.D Extension Holder	For Outside Diameter	☆	☆
Angle Head		-	-
Tail Stock & Steady Rest			
Quill Type Tail Stock		○	○
Programmable Tail Stock		-	-
Manual Type Hyd. Steady Rest		-	-
Standard Live Center (Tail Stock : Standard)		○	○
High Precision Live Center		☆	☆
2 Steps Tail Stock Pressure System		☆	☆
Quill Forward/Reverse Confirmation Device		○	○
Tail Stock Foot Switch		☆	☆
Coolant & Air Blow			
Standard Coolant (Nozzle)		●	●
Chuck Coolant (Upper Chuck)		○	○
Gun Coolant		○	○
Through Spindle Coolant (Only for Special Chuck)		☆	☆
Thru Coolant for Live Tool		-	-
Chuck Air Blow (Upper Chuck)		○	○
Tail Stock Air Blow (Upper Tail Stock)		☆	☆
Turret Air Blow		☆	☆
Air Gun		○	○
Through Spindle Air Blow (Only for Special Chuck)		☆	☆
High Pressure Coolant	0.4Bar (5.8 psi)	●	●
	6Bar (87 psi)	○	○
Power Coolant System (For Automation)		☆	☆
Coolant Chiller		☆	☆
Chip Disposal			
Coolant Tank	130 ℓ (34.3 gal)	●	●
	150 ℓ (39.6 gal)	○	○
Chip Conveyor (Hinge/Scraper)	Rear (Rear)	○	○
	Front (Right)	-	-
	Rear (Right)	○	○
Special Chip Conveyor (Drum Filter)		☆	☆
Chip Wagon	Standard (180 ℓ [47.5 gal])	○	○
	Swing (200 ℓ [52.8 gal])	○	○
	Large Swing (290 ℓ [76.6 gal])	○	○
	Large Size (330 ℓ [87.2 gal])	○	○
	Customized	☆	☆
Safety Device			
Total Splash Guard		●	●
Chuck hydraulic pressure maintenance interlock		○	○

Electric Device		E160A	E160C
Call Light	1 Color : ●	●	●
Call Light & Buzzer	3 Color : ● ● ● B	○	○
Electric Cabinet Light		○	○
Remote MPG		-	-
Work Counter	Digital	○	○
Total Counter	Digital	○	○
Tool Counter	Digital	○	○
Multi Tool Counter	Digital	○	○
Electric Circuit Breaker		○	○
AVR (Auto Voltage Regulator)		☆	☆
Transformer	20kVA	○	○
Auto Power Off		○	○
Measurement			
Q-Setter		○	○
Automatic Q-Setter		○	○
Work Close Confirmation Device (Only for Special Chuck)	TACO	○	○
	SMC	○	○
Work Setter		☆	☆
Linear Scale	X axis	-	-
	Z axis	-	-
Coolant Level Sensor (Only for Chip Conveyor)		☆	☆
Environment			
Air Conditioner		○	○
Oil Mist Collector		☆	☆
Oil Skimmer (Only for Chip Conveyor)		○	○
MQL (Minimal Quantity Lubrication)		☆	☆
Fixture & Automation			
Auto Door		○	○
Auto Shutter (Only for Automatic System)		☆	☆
Sub Operation Pannel		☆	☆
Bar Feeder Interface		○	○
Bar Feeder (FEDEK)		☆	☆
Extra M-Code 4ea		○	○
Automation Interface		☆	☆
I/O Extension (IN & OUT)	16 Contact	○	○
	32 Contact	○	○
Parts Catcher	Main SP.	○	○
Turret Work Pusher (For Automation)		☆	☆
Parts Conveyor		☆	☆
Semi Automation System		☆	☆
Hyd. Device			
Standard Hyd. Cylinder	Hollow	●	●
Standard Hyd. Unit	35bar (507.6 psi)/ 15 ℓ (4 gal)	●	●
S/W			
DNC software (HW-eDNC)		○	○
Machine Monitoring System (HW-MMS Cloud/Edge/Remote)		○	○
Machine Monitoring System & Analysis (HW-MMS Edge Plus)		☆	☆
Automation CAM program (HW-ACAM)		○	○
Conversational program (HW-DPRO)		○	○
SmartGuide-i : FANUC		●	●
Thermal Displacement Compensation (HW-TDC)		○	○
Tool Monitoring (HW-TM) : FANUC		○	○
Machine Guidance (HW-MCG) : FANUC		●	●
Energy Saving System (HW-ESS) : FANUC		●	●
Premium Tool Operation : FANUC		●	●
Manual Viewer : FANUC		●	●
Scheduling : FANUC		●	●
Operation Memo : FANUC		●	●
ETC			
Tool Box		●	●
Customized Color	Need Munsel No.	☆	☆
CAD & CAM		☆	☆

❖ Thermal Displacement Compensation device is recommended, when more than 6 bar of high pressure coolant is applied, for the high quality machining.

Specifications are subject to change without notice for improvement.

SPECIFICATIONS

Spindle Output/Torque Diagram

E160A (FANUC)

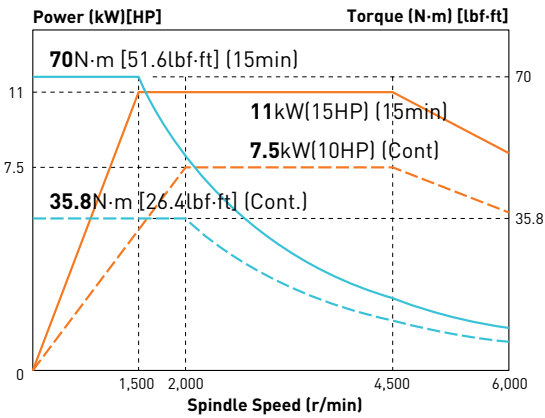

E160C (FANUC)

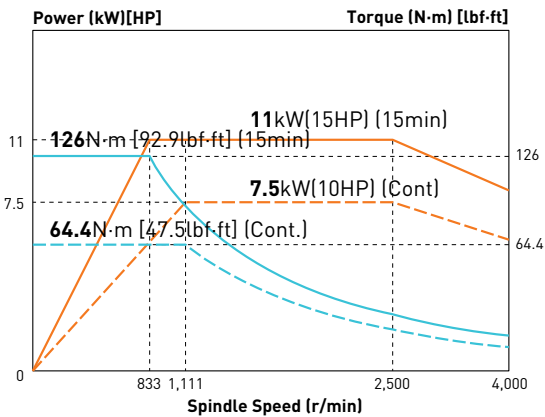

E160C (FANUC) OPTION

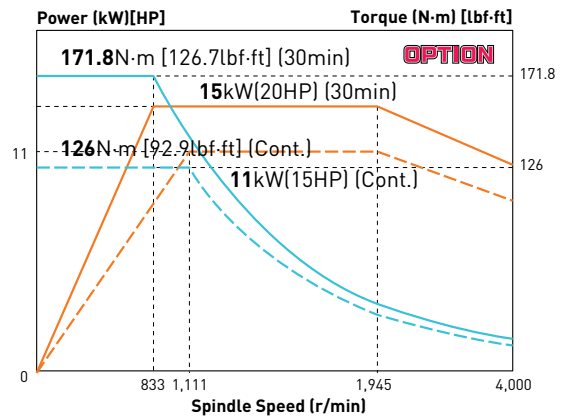

E160A (iTROL)

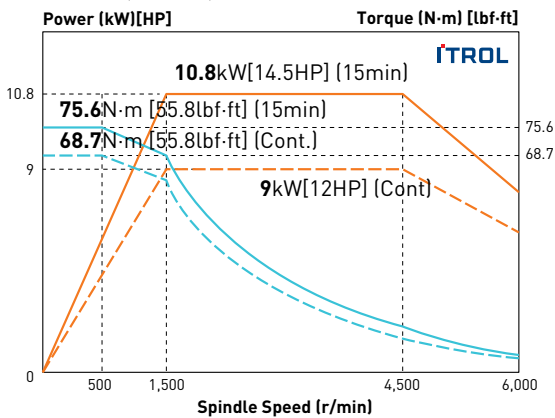

E160C (iTROL)

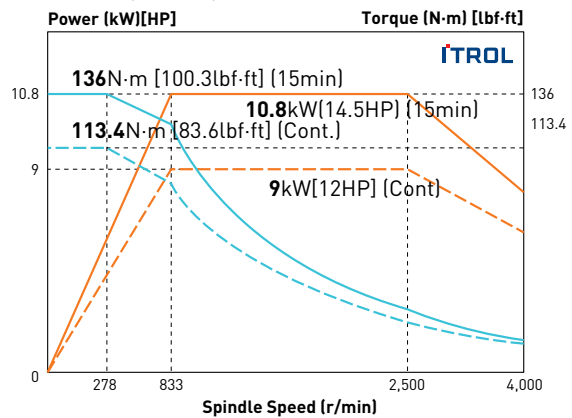

SPECIFICATIONS

External Dimensions

unit : mm(in)

E160C/A {HYUNDAI-ITROL}

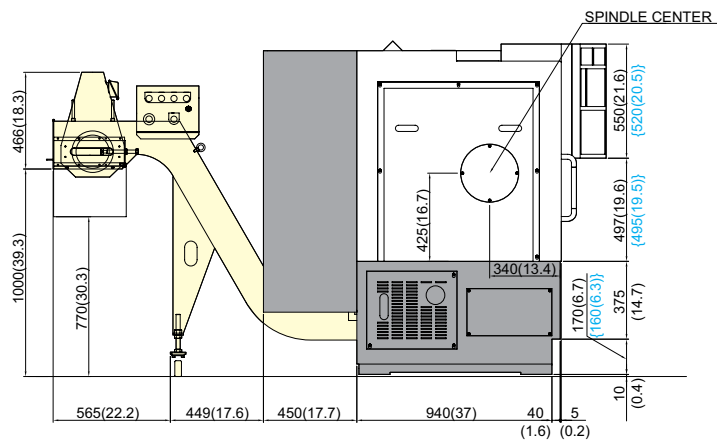
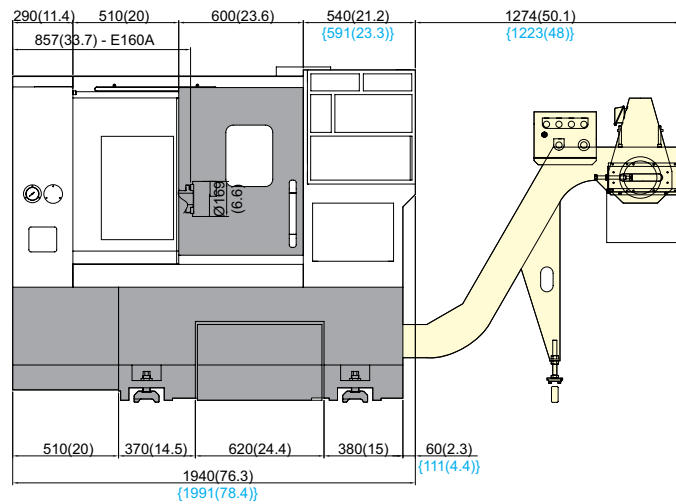
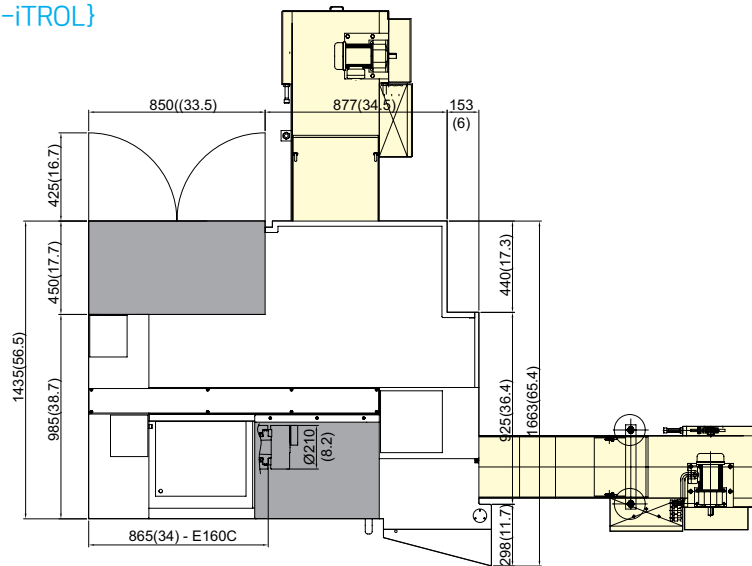

SPECIFICATIONS

Interference

unit : mm(in)

E160A

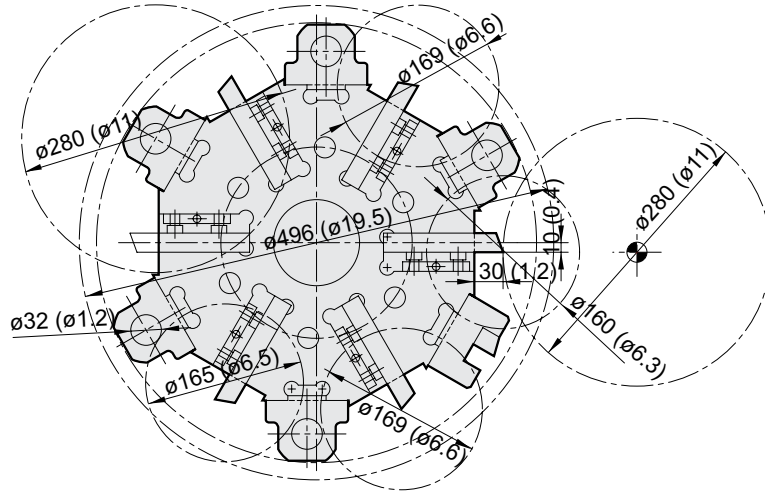

E160C

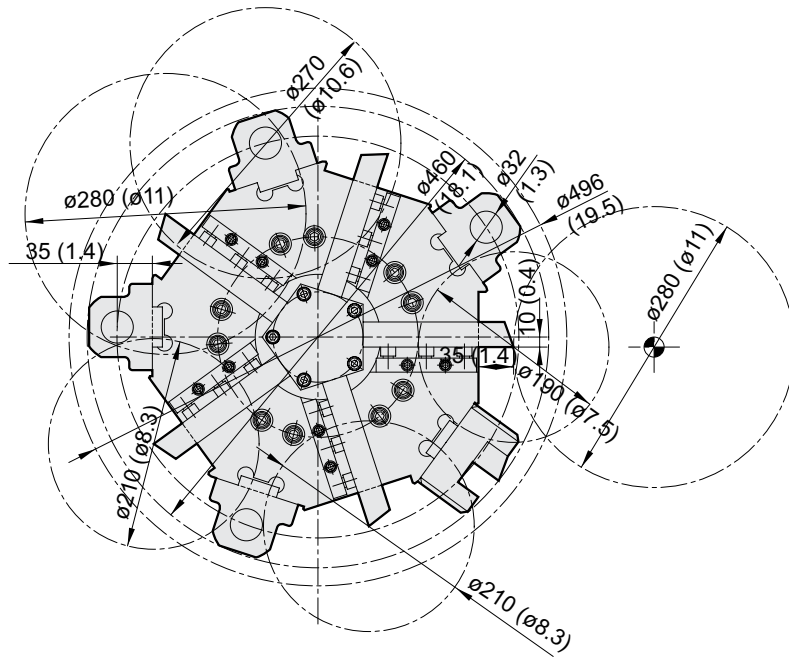

SPECIFICATIONS

Tooling System

unit : mm(in)

E160A/C

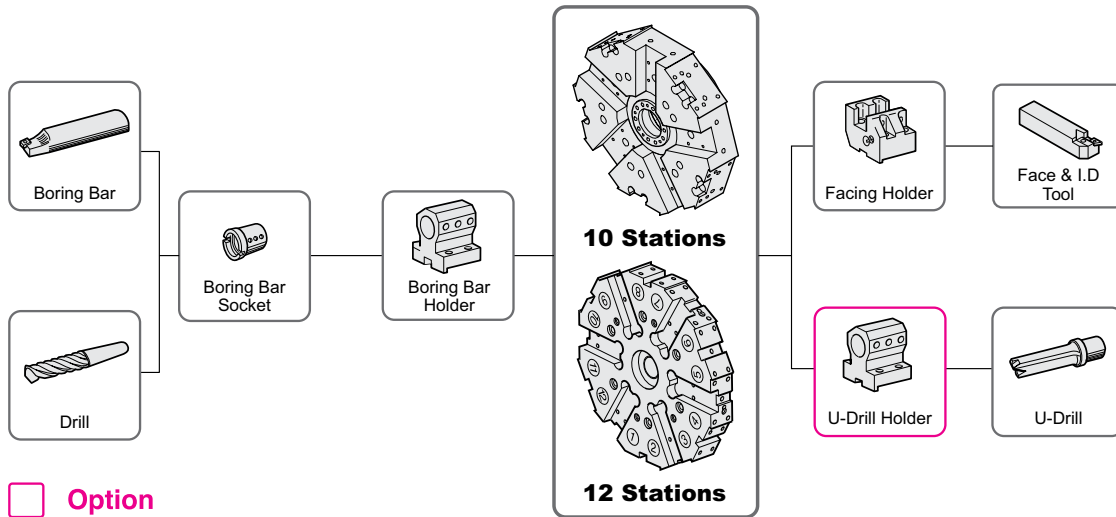

Tooling Parts Detail

ITEM			E160A		E160C	
			mm Unit	inch Unit	mm Unit	inch Unit
Turning Holder	O.D Holder	Right/Left	-	-	-	-
		Extension	Opt.	-	-	-
	Facing Holder		1	1	1	1
Boring Holder	I.D Holder	Single	5	5	4	4
		Single : $\varnothing 40$ ($\varnothing 1\ 1/2''$)	-	-	Opt.	-
	U-Drill Holder	$\varnothing 20$ ($\varnothing 3/4''$)	-	-	Opt.	-
		$\varnothing 25$ ($\varnothing 1''$)	-	-	Opt.	-
		$\varnothing 32$ ($\varnothing 1\ 1/4''$)	-	-	-	Opt.
Socket	Boring	$\varnothing 8$ ($\varnothing 5/16''$)	1	1	1	1
		$\varnothing 10$ ($\varnothing 3/8''$)	1	1	1	1
		$\varnothing 12$ ($\varnothing 1/2''$)	1	1	1	1
		$\varnothing 16$ ($\varnothing 5/8''$)	1	1	1	1
		$\varnothing 20$ ($\varnothing 3/4''$)	1	1	1	1
		$\varnothing 25$ ($\varnothing 1''$)	Opt.	1	Opt.	1
	Drill	MT 1	1	-	1	-
	ER Collet		-	-	-	-

SPECIFICATIONS

Tooling Travel Range

unit : mm(in)

With Tail Stock
 Without Tail Stock

E160A

E160C

OD tool

OD tool

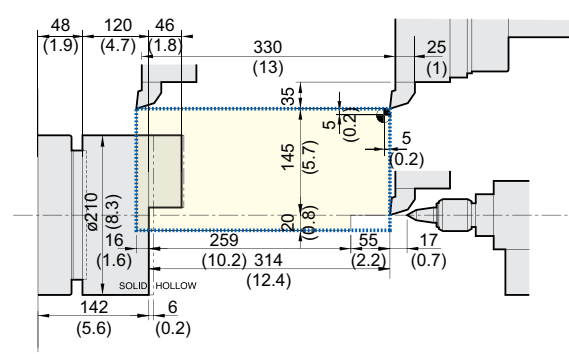
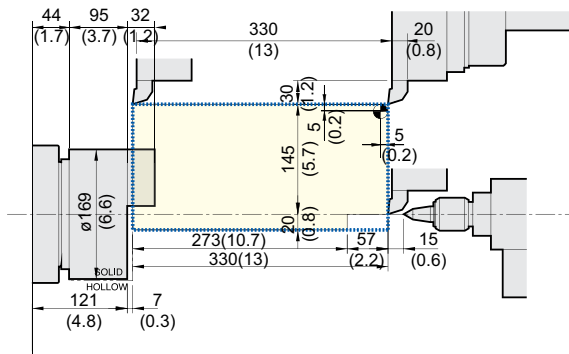

ID tool

ID tool

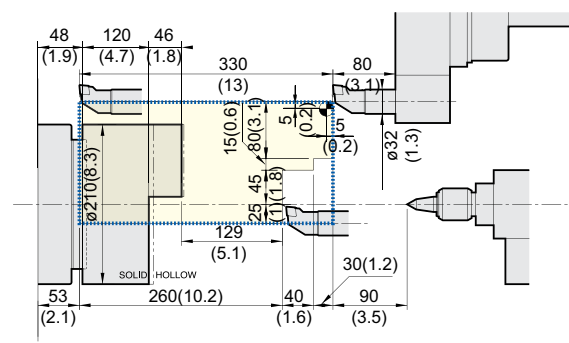
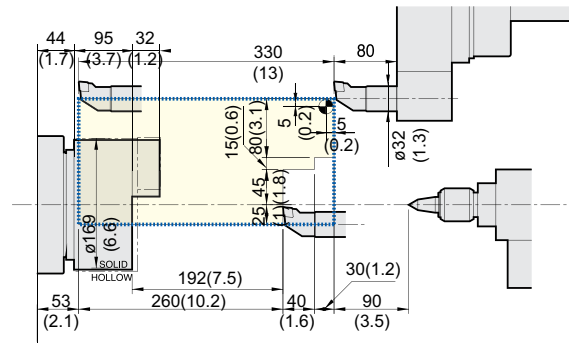

Tail stock (Opt.)

Tail stock (Opt.)

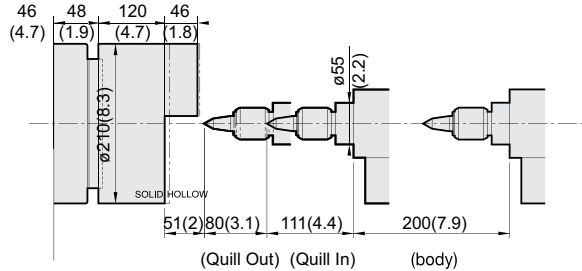
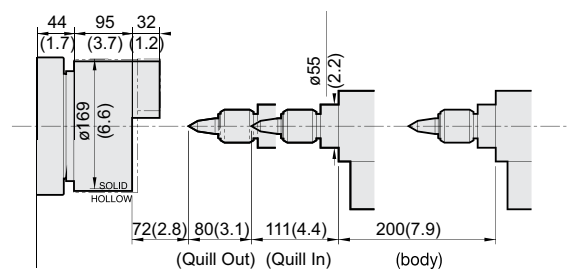

SPECIFICATIONS

Specifications

[] : Option

ITEM			E160A	E160C
CAPACITY	Swing Over the Bed	mm(in)	Ø480 (18.9")	
	Swing Over the Carriage	mm(in)	Ø285 (11.2")	
	Max. Turning Dia.	mm(in)	Ø280 (11")	
	Max. Turning Length	mm(in)	300 (11.8")	280 (11")
	Bar Capacity	mm(in)	Ø45 (1.8")	Ø51 (2")
SPINDLE	Chuck Size	inch	6"	8"
	Spindle Bore	mm(in)	Ø55 (2.2")	Ø62 (2.4")
	Spindle Speed (rpm)	r/min	6,000 [6,000]	4,000 [4,000] [4,000]
	Motor (Max/Cont.)	kw(HP)	11/7.5 (15/10) [10.8/9 (14.5/12)]	11/7.5 (15/10) [15/11 (20/15)] [10.8/9 (14.5/12)]
	Torque (Max/Cont.)	N·m(lbf·ft)	70/35.8 (51.6/26.4) [75.6/68.7 (55.8/50.7)]	126/64.4 (92.9/47.5) [171.8/126 (126.7/92.9)] [136/113.4 (100.3/83.6)]
	Spindle Type	-	BELT	
	Spindle Nose	-	A2-5	A2-6
	C-axis Indexing	deg	-	
FEED	Travel (X/Z)	mm(in)	165/330 (6.5"/13")	
	Rapid Traverse Rate (X/Z)	m/min	30/30	
	Slide Type	-	LM GUIDE	
TURRET	No. of Tools	ea	12	10
	Tool Size	OD	mm(in)	□ 20 (0.8")
		ID	mm(in)	Ø32 (1.2")
	Indexing Time	sec/step	0.1	
LIVE TOOL	Motor (Max/Cont.)	kw(HP)	-	
	Milling Tool Speed (rpm)	r/min	-	
	Torque (Max/Cont.)	N·m(lbf·ft)	-	
	Collet Size	mm(in)	-	
	Type	-	-	
TAIL STOCK	Taper	-	[MT4]	
	Quill Dia.	mm(in)	[Ø55 (2.2")]	
	Quill Travel	mm(in)	[80]	
	Travel	mm(in)	[200 (3.1")]	
TANK CAPACITY	Coolant Tank	ℓ (gal)	130 (34.3)	
	Lubricating Tank	ℓ (gal)	1.8 (0.5)	
POWER SUPPLY	Electric Power Supply	kVA	13	
	Thickness of Power Cable	Sq	Over 16	
	Voltage	V/Hz	220/60 (200/50*)	
MACHINE	Floor Space (L×W)	mm(in)	1,940×1,660 (76.4"×65.4") [1,991×1,660 (78.4"×65.4")]	
	Height	mm(in)	1,602 (63.1")	
	Weight	kg(lb)	2,400 (5,291)	2,500 (5,511)
PC	Controller	-	HYUNDAI WIA FANUC i Series - Smart Plus [HYUNDAI-iTROL]	

*) Using 50Hz voltage instead of 60Hz may lower the output of motors. (excluding servo motors and inverter motors)
Specifications are subject to change without notice for improvement.

CONTROLLER

HYUNDAI WIA FANUC i Series – Smart Plus

[] : Option

Controlled axis / Display / Accuracy Compensation	
Control axes	2 axes (X, Z) / 3 axes (X, Z, C) / 4 axes (X,Z,Y,C) 5 axes (X, Z, B, C, A) / 6 axes (X, Z, Y, B, C, A) 7 axes (X1/Z1, X2/Z2, B2, C1/C2)
Simultaneously controlled axes	2 axes [Max. 4 axes]
Designation of spindle axes	3 axes [Max. 4 axes]
Least setting Unit	X, Z, Y, B axes : 0.001 mm (0.0001 inch) C, A axes : 0.001 deg
Least input increment	X, Z, Y, B axes : 0.001 mm (0.0001 inch) C, A axes : 0.001 deg
Inch / Metric conversion	G20 / G21
High response vector control	
Interlock	All axes / Each axis
Machine lock	All axes
Backlash compensation	± 0~9999 pulses (exc. Rapid traverse / Cutting feed)
Position switch	
LCD / MDI	15 inch LCD unit (with Touch Panel)
Feedback	Absolute motor feedback
Stored stroke check 1	Over travel
Stored stroke check 2, 3	
PMC axis control	
Operation	
Automatic operation (Memory)	
MDI operation	
DNC operation	Needed DNC software / CF card
Program restart	
Wrong operation prevention	
Program check function	Dry run
Single block	
Search function	Program Number / Sequence Number
Interpolation functions	
Nano interpolation	
Positioning	G00
Linear interpolation	G01
Circular interpolation	G02, G03
Exact stop mode	Single : G09, Continuous : G61
Dwell	G04, 0 ~ 9999.9999 sec
Skip	G31
Reference position return	1st reference : G28, 2nd reference : G30 Ref. position check : G27
Thread synchronous cutting	G33
Thread cutting retract	
Variable lead thread cutting	
Multi / Continuous threading	
Feed function / Acc. & Dec. control	
Manual feed	Rapid traverse Jog : 0~2,000 mm/min (79 ipm) Manual handle : x1, x10, x100 pulses Reference position return
Cutting Feed command	Direct input F code
Feedrate override	0 ~ 200% (10% Unit)
Rapid traverse override	1%, F25%, 50%, 100%
Override cancel	
Feed per minute	G98
Feed per revolution	G99
Look-ahead block	1 block
Program input	
Tape Code	EIA / ISO
Optional block skip	9 ea
Program stop / end	M00, M01 / M02, M30
Maximum command unit	± 999,999.999 mm (± 99,999.9999 inch)
Plane selection	X-Y : G17 / Z-X : G18 / Y-Z : G19
Workpiece coordinate system	G52, G53, 6 pairs (G54 ~ G59)
Manual absolute	Fixed ON
Programmable data input	G10
Sub program call	10 folds nested
Custom macro	#100 ~ #199, #500 ~ #999
G code system	A, B/C
Programmable mirror image	G51.1, G50.1
G code preventing buffering	G4.1
Direct drawing dimension program	Including Chamfering / Corner R
Conversational Program	SmartGuide-i

Program input	
Multiple repetitive cycles	I, II
Canned cycle for turning	
Auxiliary function / Spindle speed function	
Auxiliary function	M & 4 digit
Level-up M Code	High speed / Multi / Bypass M code
Spindle speed function	S & 5 digit, Binary output
Spindle override	0% ~ 150% (10% Unit)
Multi position spindle orientation	M19 (S##)
FSSB Rigid tapping	
Constant surface speed control	G96, G97
Tool function / Tool compensation	
Tool function	T & 2 digit + Offset 2 digit
Tool life management	
Tool offset pairs	128 pairs
Tool nose radius compensation	G40, G41, G42
Geometry / Wear compensation	
Direct input of offset measured B	
Editing function	
Part program storage size	5,120m (2MB)
No. of registerable programs	1,000 ea
Program protect	
Background editing	
Extended part program editing	Copy, move and change of NC program
Memory card program edit	
Data input / output & Interface	
I/O interface	CF card, USB memory Embedded Ethernet interface
Screen hard copy	
External message	
External key input	
External workpiece number search	
Automatic data backup	
Setting, display and diagnosis	
Self-diagnosis function	
History display & Operation	Alarm & Operator message & Operation
Run hour / Parts count display	
Maintenance information	
Actual cutting feedrate display	
Display of spindle speed / T code	
Graphic display	
Operating monitor screen	Spindle / Servo load etc.
Power consumption monitoring	Spindle & Servo
Spindle / Servo setting screen	
Multi language display	Support 24 languages
Display language switching	Selection of 5 optional Languages
LCD Screen Saver	Screen saver
Unexpected disturbance torque	BST (Back spin torque limit)
Function for machine type	
Cs contour control (C & A axes)	Mill, MS, Y, SY, LF-Mill, TTMS, TTSY
Polar coordinate interpolation	Mill, MS, Y, SY, LF-Mill, TTMS, TTSY
Cylindrical interpolation	Mill, MS, Y, SY, LF-Mill, TTMS, TTSY
Polygon turning (2 Spindles)	Mill, MS, Y, SY, LF-Mill, TTMS, TTSY
Canned cycle for drilling	Mill, MS, Y, SY, LF-Mill, TTMS, TTSY
Spindle orientation expansion	MS, SY, TTS, TTMS, TTSY
Spindle synchronous control	MS, SY, TTS, TTMS, TTSY
Torque control	MS, SY, TTS, TTMS, TTSY
Y axis offset	Y, SY, TTSY
Arbitrary angular control	Y, SY, TTSY
Composite / Superimposed control	MS, SY, TTS, TTMS, TTSY
Balance cutting	TTS, TTMS, TTSY
Option	
Fast ethernet	Needed option board
Data server	Needed option board
Protection of data at 8 levels	
Tool offset pairs	200 pairs
Helical interpolation	
Optional block skip	40 ea, 200 ea (AICC II)

Figures in inch are converted from metric values.

The FANUC controller specifications are subject to change based on the policy of company CNC supplying.

CONTROLLER

HYUNDAI-iTROL (SIEMENS 828D)

[] : Option ☆ Needed technical consultation

Controlled axis / Display / Accuracy Compensation	
Control axes	2 axes (X, Z) - Std.
	3 axes (X, Z, C) - Mill
	4 axes (X, Z, Y, C) - Y
	5 axes (X, Z, B, C, A) - MS
	6 axes (X, Z, Y, B, C, A) - SY
	Max. 4 axes
Simultaneously controlled axes	Max. 4 axes
Least setting Unit	X, Z, Y, B axes : 0.001 mm (0.0001 inch)
	C, A axes : 1 deg [0.001] deg
Least input increment	X, Z, Y, B axes : 0.001 mm (0.0001 inch)
	C, A axes : 1 deg [0.001] deg
Inch / Metric changeover	G70 (inch) / G71 (metric)
Interlock	All axes / Each axis
Backlash compensation	
Pitch error compensation	Leadscrew pitch error compensation
LCD / MDI	10.4 inch color LCD
	[15 inch color LCD (With Touch panel)]
Keyboard	QWERTY full keyboard
Stored stroke check	Over travel
Operation	
Automatic operation	
MDI operation	
Program restart	
Program check function	Dry run / Program check / Machine lock
Single block	
Block search	Block search
Reposition	
Working area limit	Working area limitations
Interpolation functions	
Positioning	G00
Linear interpolation	G01
Circular interpolation	Circular interpolation CW (G02)
	Circular interpolation CCW (G03)
	Single block exact stop (G09)
Exact position stop	Exact stop G60 (G601, G602, G603)
Dwell	Dwell (G04)
Reference position return	Return to reference point
	Return to 2nd reference point
Helical interpolation	
Thread synchronous cutting	
Thread cutting retract	
Spline interpolation	Non-uniform rational B splines
Feed function / Acc. & Dec. control	
Manual feed	Rapid traverse
	Jog
	Manual handle
	Reference position return
Cutting Feed command	Direct input F code
Feedrate override	0 ~ 200% (10% Unit)
Rapid traverse override	1%, 25%, 50%, 100%
Feed per minute	G94
Feed per revolution	G95
Look-ahead block	1 block
Program input	
ISO support	G291 (ISO) / G290 (SIEMENS)
	(ISO G Code system-A)
Optional block skip	2
Program stop / end	M00, M01 / M02, M30
Maximum command unit	± 999,999.999 mm, ± 99,999.9999 inch
Plane selection	X-Y : G17, X-Z : G18, Y-Z : G19
	G54 ~ G57, G505~G549
Workpiece coordinate system	G500 (Basic frame - settable zero offset)
	G53 (Work offset non modal)
	G153 (basic frame non modal)
Sub program call	11 folds nested
G code preventing buffering	STOPRE
Turning Cycle	Turning programing (Cycle 93, 94, 95, 97)
User Cycle	

Auxiliary function / Spindle speed function	
Auxiliary function	M Code 4 digit
Spindle speed function	S Code 5 digit
Spindle override	0% ~ 150% (10% Unit)
Spindle orientation	SPOS
Rigid tapping	
Automatic mode interchange	Spindle / Axis mode
Constant surface speed control	G96, G97
Spindle speed limitation	LIMS
Tool function / Tool compensation	
Tool function	Tool number & Tool name
	Tool : T + Offset : D
Tool life management	128 ea : Std.
	256 ea : Mill
	768 ea : Y, MS, SY
Cutting Edges in tool list	256 ea : Std.
	512 ea : Mill
Tool nose radius compensation	1,536 ea : Y, MS, SY
	ISO (G40, G41, G42)
Geometry / Wear compensation	
Measurement of tool length	
Tool management function	
Editing function	
Part program storage size	3MB - Std.
	5MB - Mill
No. of registerable programs	10MB - Y, MS, SY
	750 ea
External Storage devices	Local network, Server, USB, Flash drive
Background editing	
Extended part program editing	Copy, move and change of NC program
Memory card program edit	
Data input / output & Interface	
I/O interface	CF card interface (ONLY 10.4")
	USB memory interface
	Embedded Ethernet memory interface
Screenshot	
Setting, display and diagnosis	
Self-diagnosis function	
History display & Operation	Alarm & Operator message & Operation
Run hour / Parts count display	
Maintenance information	
Actual cutting feedrate display	
Display of spindle speed / T code	
Graphic display	
Operating monitor screen	Spindle / Servo load etc.
	Support 9 languages
Multi language display	Chinese (Simplified/Traditional), English, French, German, Italian, Korean, Portuguese, Spanish
	[☆ Support 22 languages : Inquiry need]
LCD Screen Saver	Screen saver & Motion sensing
Function for machine type	
Cs contour control (C & A axes)	Mill, MS, Y, SY model
Polar coordinate interpolation	Mill, MS, Y, SY model
Cylindrical interpolation	Mill, MS, Y, SY model
Canned cycle for drilling	Mill, MS, Y, SY model
[Polygon turning (CP-Basic)]	Mill, MS, Y, SY model
[Hobbing / Skybing (CP-Comfort)]	Mill, MS, Y, SY model
Spindle synchronous control	MS, SY model
Servo tailstock function	MS, SY model
Option	
Additional optional block skip	10
Contour handwheel	
3D simulation	
Real time simulation	
Shop Turn	Machining step programming for turning

HW-MMS

HYUNDAI WIA Machine Monitoring System



A manufacturing machine self-developed by Hyundai Wia, HW-MMS is a unique software capable of monitoring the operation status of manufacturing machines in factories, a smart solution to improve manufacturing conditions of customers

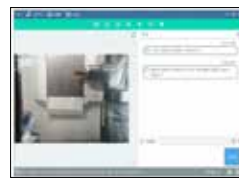
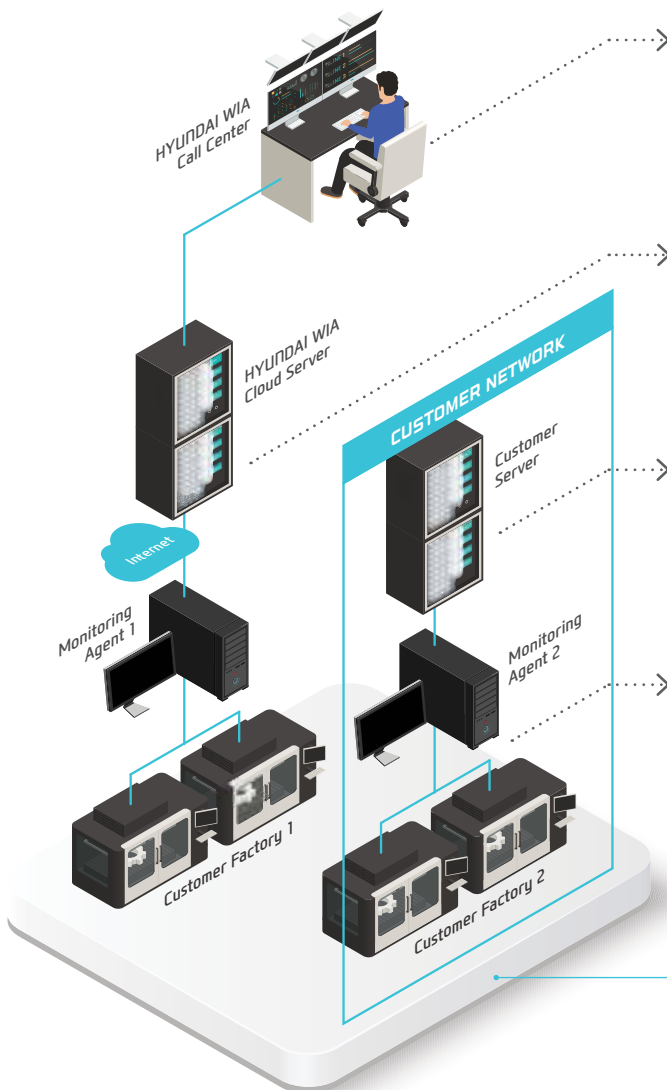

HW-MMS Remote

Hyundai Wia Call Center's remote diagnosis service provides a HMI/video diagnostic function.



HW-MMS Cloud

A cloud server-based equipment monitoring system for collecting and analyzing facility operation data.



HW-MMS Edge

A client server-based tool monitoring system for collection/analysis of facility operation data. (Compatible with client MES / ERP interface)



HW-MMS Edge Plus

This is a facility big data-based smart factory solution that collects and analyzes spindle/feed data, tool lifespan, PC processing files, etc. in real time

HYUNDAI WIA
Smart Factory Solution



You Tube HYUNDAI WIA MT
www.youtube.com/HYUNDAIWIAMT

EXPERIENCE THE NEW TECHNOLOGY

With its top-quality HYUNDAI WIA machine tool creates a new and better world.



<http://machine.hyundai-wia.com>
HYUNDAI WIA Machine Tools
Global Links

HEADQUARTER

Changwon Technical Center/R&D Center/Factory 153, Jeongdong-ro, Seongsan-gu, Changwon-si, Gyeongsangnam-do, Korea TEL : +82 55 280 9114 FAX : +82 55 282 9114

Overseas Sales Team /R&D Center 37, Cheoldobangmulgwan-ro, Uiwang-si, Gyeonggi-do, Korea TEL : +82 31 8090 2539

OVERSEAS OFFICES

HYUNDAI WIA Machine America corp. 450 Commerce Blvd, Carlstadt, NJ 07072, USA TEL : +1-201-987-7298

HYUNDAI WIA Europe GmbH Alexander-Fleming-Ring 57, 65428 Rüsselsheim Germany TEL : +49-0-6142-9256-0

HYUNDAI WIA Machine Tools China 2-3F, Bldg6, No.1535 Hongmei Road, Xuhui District, Shanghai, China TEL : +86-21-6427-9885

India Branch Office #4/169, 1st Floor, LOTTE BLDG, Rajiv Gandhi Salai, (OMR), Kandanchavadi, Chennai - 600096, Tamilnadu, India TEL : +91-76-0490-3348

Vietnam Branch Office Flat number 05, Service and Trade Center of Viet Huong Industrial Zone, Highway 13, Thuan Giao, Thuan An, Binh Duong, Vietnam TEL : +84-3-5399-5099

2021-06 001.004 ENG