

# HD 2600/3100 Series

HD2600/M | HD3100A/MA | HD3100/M/L/LM

HYUNDAI WIA Heavy Duty Cutting CNC Turning Center

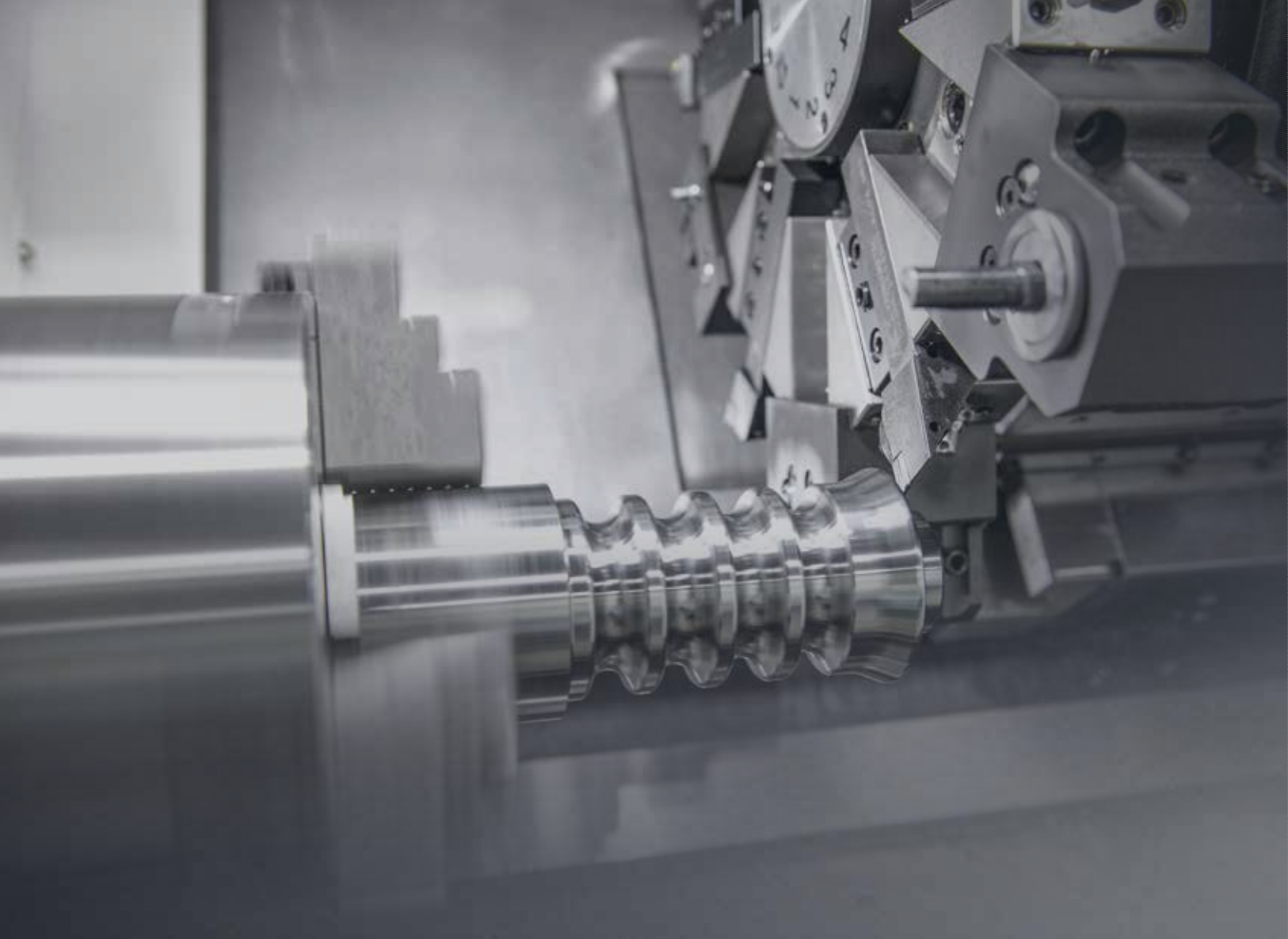

# Technical Leader

The CNC Turning Center HD2600/3100 Series, designed by Hyundai WIA with years of expertise and the latest technology, is a Turning Center that maximizes productivity and performance.

ITEM	Chuck		Bed (Z-Axis)			Standard Turret		Mill Turret	
	10"	12"	680mm	830mm	1,350mm	10 Station	12 Station	BMT55P	BMT65P
HD2600	●	○	●			●	○		
HD2600M	●		●					●	
HD3100A	●			●		●	○		
HD3100MA	●			●					●
HD3100		●		●		●	○		
HD3100M		●		●					●
HD3100L		●			●	●	○		
HD3100LM		●			●				●

●: Standard ○: Option

# HD

## 2600/3100 Series

Lathe with Box Guideways for Heavy Cutting

- Box guideways for heavy-duty cutting
- Stabilized unit structure to minimize thermal displacement
- User convenient structure for high productivity
- Excellent rapid traverse rate: 30m/min [1,181ipm] (Z-axis)
- High-rigidity and high-speed servo turret (Expanded disk width)
- Ergonomic design for convenient access to chuck and tool



# 01 BASIC STRUCTURE

High Productivity 10/12inch CNC Turning Center for Heavy Duty Cutting

## Turret

- 10 [Opt. 12] EA
- O.D./I.D. :  $\square 25/\varnothing 50$
- HD2600M : BMT55
- HD3100MA | HD3100M/LM : BMT65

## Tail Stock

- MT#5
- Quill Dia. :  $\varnothing 100$  (3.9")
- Quill Travel : 120 mm (4.7")

## High Precision Spindle

- Integral body & heat dissipating RIB structure.
- HD2600/3100A Series : 10"
- HD3100 Series : 12"
- C-Axis Control : 0.001° ('M' Type)

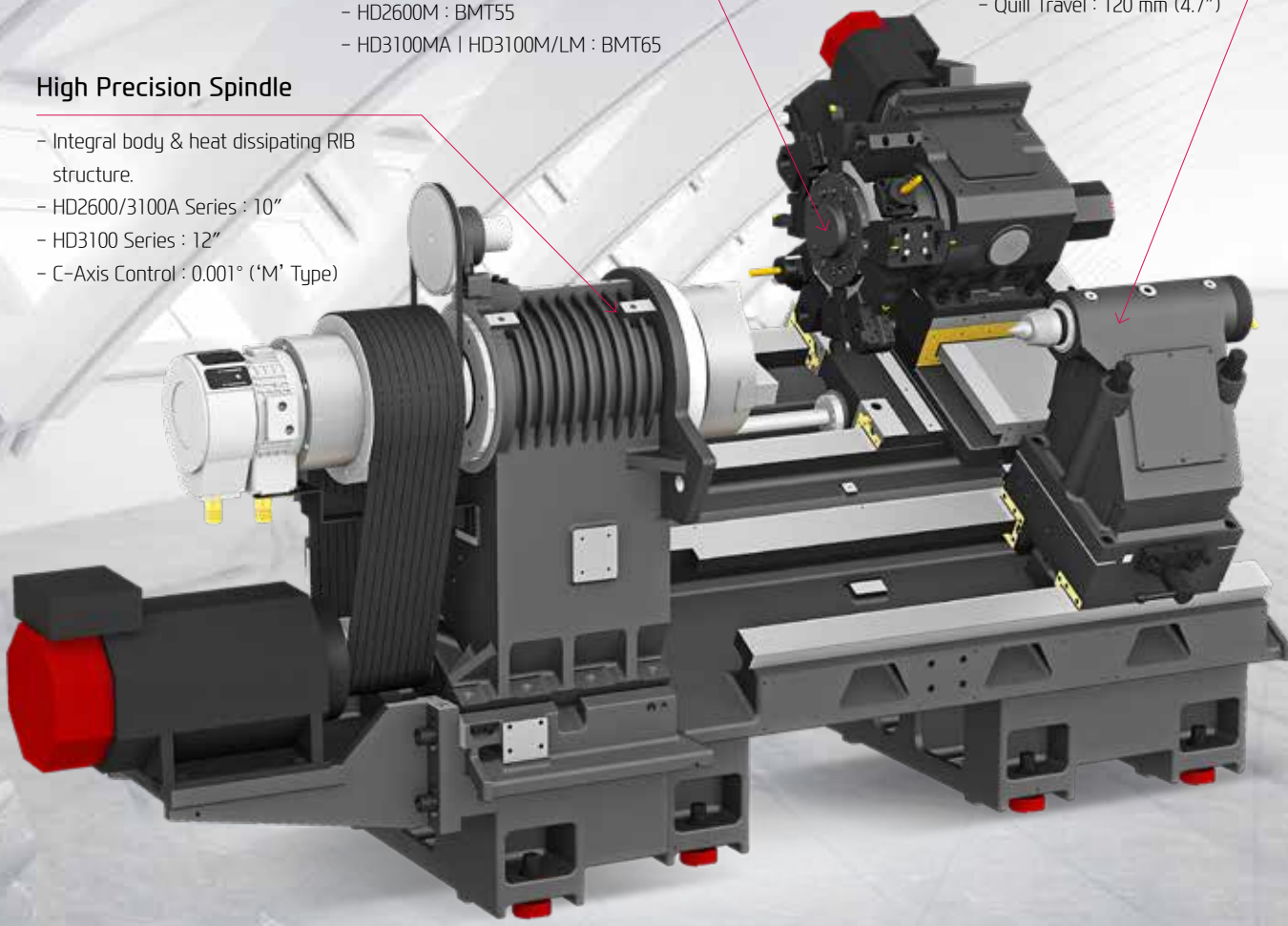

# POWERFUL CUTTING CAPABILITY & WIDE CUTTING AREA

## ALL-IN-ONE TYPE OF BED

### Optimal Structural Analysis

Structural analysis was applied to the design of the machine to increase the tool post body and reduce the machine's height so as to maintain the bed's dynamic rigidity even during heavy-duty cutting.

In addition, the HD2600/3100's bed slope is pitched at 30° to ensure more stable machining.



### Integrated Coolant Tank

The structure is designed with the coolant tank installed at the bed front for improved convenience. Chips can be removed from the right side of the machine.

## GUIDEWAY

### Box Guideway on All Axes

With the mounting of box guideways on all axes, the machine offers excellent vibration absorption even against during heavy-duty cutting, enabling high-quality machining.

### Closed-type GIB Structure

The guide attachment surface of X-axis guideway has been changed to a sealed GIB structure to minimize X-axis turcite damage caused by chips. As a result, the machining capacity has been greatly enhanced too.

Rapid Traverse Rate (X/Z axis) : 24/30 m/min (945/1,181 ipm)



6-Face constraint design for improved travel capacity

### Travel (X/Z)

HD2600/M	HD3100A/MA HD3100/M	HD3100L/LM
<b>265/680</b> mm (10.4"/26.8")	<b>265/830</b> mm (10.4"/32.7")	<b>265/1,350</b> mm (10.4"/53.1")

# 02 HIGH PRECISION SPINDLE

Long Lasting, High Accuracy & Excellent Performance CNC Turning Center



## Spindle Specifications

[ ] : Option

Model	Speed r/min	Motor (Max./Cont.)	Max. Torque
HD2600	3,500 [2,800 rpm]	26/18.5 kW (35/25 HP)	734 [1,123] N·m (541.4 [828.7] lbf.ft)
HD2600M	3,500 rpm	26/18.5 kW (35/25 HP)	734 N·m (541.4 lbf.ft)
HD3100A/MA	3,500 rpm	26/18.5 kW (35/25 HP)	734 N·m (541.4 lbf.ft)
HD3100/L	2,800 rpm	26/18.5 [35/32] kW (35/25 [47/29.5] HP)	1,123 [1,613] N·m (828.7 [1,189.7] lbf.ft)
HD3100M/LM	2,800 rpm	26/18.5 kW (35/25 HP)	1,123 N·m (828.7 lbf.ft)

# HEAVY DUTY CUTTING & HIGH ACCURACY

## SPINDLE

### Spindle Ideal for Heavy Cutting

The HD2600 and HD3100 feature torque of 734N·m and 1,123N·m, respectively, ensuring excellent performance in heavy-duty cutting, interrupted cutting, and so on. (specially designed for extra heavy workpiece)

In particular, the HD3100 features a gear spindle as an option [gear : 1,613N·m torque], thus meeting customer needs for a stronger heavy-duty cutting function.

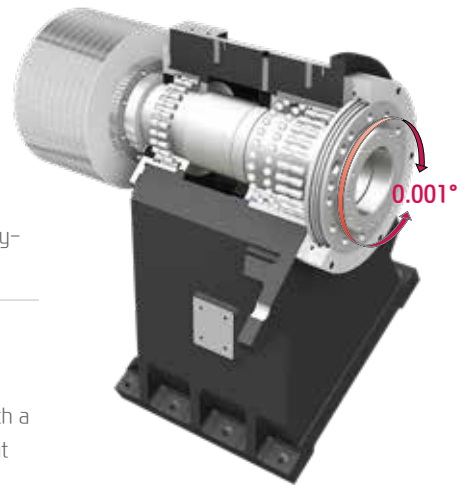

### Ribstar Belt

Also, machining performance is enhanced by **applying ribstar belt** to minimize noise and belt slipping problems. The spindle is designed with a **labyrinth structure** to minimize possible bearing damage from coolant and to improve machining stability.

### C-Axis Control ('M' Type)

C-axis of HD2600M/3100M Series can be controlled to 0.001° which makes it possible to process various shapes.

## TAIL STOCK

### MT#5 Tail Stock

The HD2600 and HD3100 are fitted with tailstocks as a standard for excellent machining quality. In addition, the travel distance of quill can be as long as 120mm (4.7"), thus expanding the support area.

- ◎ Quill Dia. :  $\varnothing 100$  mm (3.9")
- ◎ Quill Travel : 120 mm (4.7")
- ◎ Reinforced Tailstock Rigidity : Thrust 742 kgf → 989 kgf



# 03 SERVO TURRET

High speed, High Accuracy, Highly Reliable Servo Turret

## Servo Turret

[ ] : Option

No. of Tools	Tool Size (O.D/I.D)	Indexing Time
10 [12] <small>EA</small>	□ 25/Ø50 mm (□ 1"/Ø2")	0.15 <small>sec</small>

\* HD2600M : □ 25/Ø40 mm (□ 1"/Ø1 1/2")

## Mill Turret

[ ] : High-Torque Option

Model	Type	Speed	Motor (Max./Cont)	Torque (Max./Cont)
HD2600M	BMT55	6,000 rpm	5.5/3.7 kW (7.4/5 HP)	52.5/26.5 N·m (38.7/19.5 lbf.ft)
HD3100MA HD3100M/LM	BMT65	5,000 rpm	5.5/3.7 kW (7.4/5 HP)	70/35.4 N·m (51.6/26.1 lbf.ft)
		[5,000 rpm]	[7.5/3.7 kW (10/5 HP)]	95.5/35.4 N·m (70.4/26.1 lbf.ft)



# VARIOUS DRIVEN PRECISION VDI TOOL HOLDERS

## TURRET

### Servo Turret

The turret of HD2600/3100 series is joined with a high performance AC servo motor, improving machining reliability.

The 3-piece coupling shows excellent performance in indexing. Powerful hydraulic tool clamping minimizes tool tip deviation caused by workload.



### High Pressure Coolant **OPTION**

Turret is designed to utilize 20 bar (290 psi) high pressure coolant and it shows optimum performance in machining difficult-to-cut material.

⊙ Static-Rigidity Increased : I.D **20%**, O.D **3%** ↑

HD2600	90 mm (3.5")	<b>20% UP</b>
HD3100/A	120 mm (4.7")	<b>20% UP</b>

### BMT Turret

BMT turret where each holder is fixed with 4 screws, shows outstanding performance in milling, drilling and tapping during heavy-duty cutting.

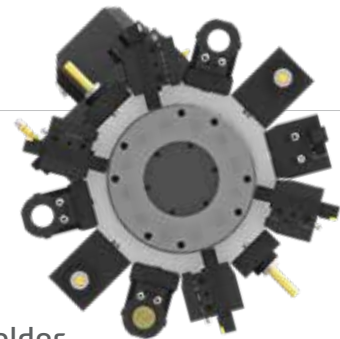

STRAIGHT MILLING HEAD



ANGULAR MILLING HEAD



### Mill Tool Holder

Machining capability has increased with the addition of straight milling head tool holder, which can machine workpieces from the side, and angular milling head tool holder, which can perform I.D. operations.



### Special Tool

**OPTION**

The HD2600/3100 series can process high value-added products using a variety of rotating tools. In particular, there is a multi-holder for attaching a variety of tools to one holder, and an eccentric rotary tool for handling eccentric parts without additional axis travel, which can realize integration of process with one machine.

❖ Consultation needed when ordering these options.

# 04 USER CONVENIENCE

Various Devices for User Friendly

## BAR FEEDER SYSTEM

### Bar Feeder

Bar feeder system enables automation which leads to efficiency improvement.

Long Type	: 3 m (118.1")	Short Type	: 1.5 m (59.1")
Bar Capacity	: Ø42 (1.7")	Bar Capacity	: Ø65 (2.6")



#### Parts Catcher

An optional parts catcher collects finished parts without the need to open the door, adding productivity, especially when a bar feeder is attached.



#### Auto Door

Using M-code, the doors can be automatically opened and closed which brings productivity and convenience for automation.



#### Parts Conveyor

The parts conveyor transfers the finished workpiece unloaded by the parts catcher for user convenience.



#### Auto Shutter

Using auto shutter, automation system with gantry loader is possible without opening the machine's door.

## HIGH PRECISION SYSTEM



### Automatic Q-Setter

Cutting tools are calibrated quickly and accurately with the addition of a q-setter. Each tool tip is touched off manually using a sensor that inputs the position automatically.



### Linear Scale

Linear scales increase positioning accuracy and reduce distortion caused by thermal growth, thus ensuring a more accurate finished part



### Work Probe

Workpiece coordinate values can be set automatically using the optional spindle probe.

Optional

## GANTRY LOADER SYSTEM

### Gantry Loader Machining Process

The high speed gantry loaders and the work stocker allow the implementation of automation cells. This enables flexible machining process and productivity enhancement. Optimization of the installation space is also possible.

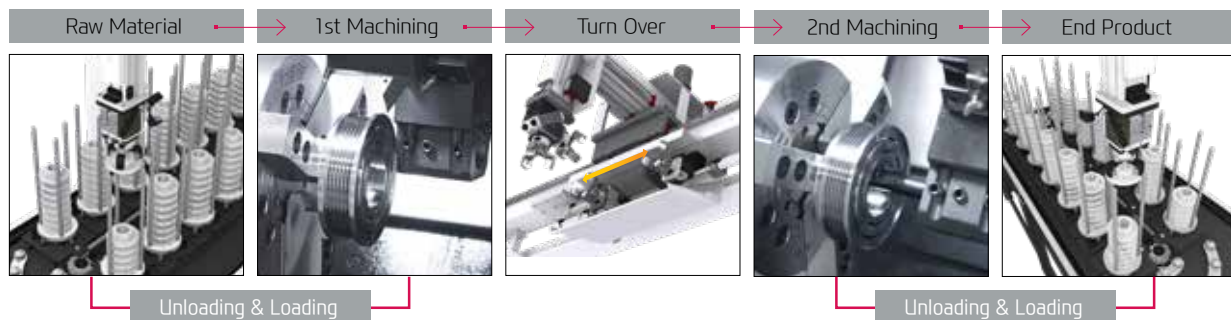

## COOLANT UNIT & ECO SYSTEM



Standard Coolant (Nozzle)

Chuck Coolant (Upper Chuck)

Chuck Air Blow (Upper Chuck)

Air Gun



MQL : Minimal Quantity Lubrication

Oil Skimmer

Mist Collector

Lubrication Device

# 05 HYUNDAI WIA FANUC – SMART PLUS

The Compatible All-round Control



**15" Touch-type Monitor as a standard**

	Fast Cycle Time Technology
Smart Machine Control	Fine Surface Technology
	Smart Servo Control Technology
Conversational Program	SmartGuide-i
i-HMI	Machining-aid Function
Part Program Storage	5120M (2MB)
No. of Registerable Programs	1000 EA



# SMART SOFTWARE



## Dialogue Program (Smart Guide-i)

This software offers the maximum user convenience through dialogue manipulation from setup to processing. This includes writing processing programs and simulation checks.

## Convenience Function S/W

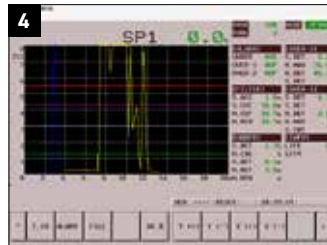

### 1. Thermal Displacement Compensation (HW-TDC) **OPTION**

This software improves processing precision by minimizing thermal deformation from changes in external environments and machining.

### 2. Machine Guidance (HW-MCG)

This software offers various user convenience functions such as tool manipulation, maintenance, tool monitoring, and a pop-up/status

### 3. LAUNCHER

This software offers shortcuts for quick access to specialized features and frequently used features.

### 4. Tool Monitoring (HW-TM) **OPTION**

This tool status monitoring software monitors and protects workpiece, tools, and equipment through real-time monitoring of the motor load from machining.

## Machining Support S/W



### 1. Premium Tool Operation

This software offers premium graphic functions for more intuitive tool operation. (Only in iHMI tools)

### 2. Manual Viewer

This software enables users to view electronic manuals right from the tool. (Only in iHMI tools)

### 3. Scheduling

This software enables viewing/setting up directly from the tool. This allows such actions as managing customer's tool schedules and schedule notification. (Only in iHMI tools)

### 4. Operation Memo

This software is capable of managing customer notes such as tool information and issues. (Only in iHMI tools)

# SPECIFICATIONS

## Standard & Optional

Spindle		HD2600	HD2600M
12" Headstock		○	-
Main Spindle	10"	●	●
Hollow Chuck 3 Jaw	12"	○	○
Main Spindle	10"	○	○
Solid Chuck 3 Jaw	12"	-	-
Belt Type		●	●
Gear Type		-	-
Standard Soft Jaw (1set)		●	●
Chuck Clamp Foot Switch		●	●
2 Steps Hyd. Pressure Device		○	○
Spindle Inside Stopper		☆	☆
5" Index		-	-
Cs-Axis (0.001")		-	●
Chuck Open/Close Confirmation Device		●	●
2 Steps Chuck Foot Switch		○	○
<b>Turret</b>			
Tool Holder		●	●
Mill Turret	BMT	-	●
Straight Milling Head (Axial)	Collet Type,2ea	-	●
Angular Milling Head (Radial)	Collet Type,2ea	-	●
Straight Milling Head (Axial)	Adapter Type	-	-
Angular Milling Head (Radial)	Adapter Type	-	-
Boring Sleeve		●	●
Drill Socket		○	○
U-Drill Holder		●	●
O.D Extension Holder	For Out-Dia	●	-
Angle Head		-	-
<b>Tail Stock &amp; Steady Rest</b>			
Quill Type Tail Stock	MT#4	-	-
	MT#5	●	●
Built-in Tail Stock	MT#4	○	○
Programmable Tail Stock		○	○
Manual Type Hyd. Steady Rest		-	-
Standard Live Center		●	●
High Precision Live Center		☆	☆
2 Steps Tail Stock Pressure System		○	○
Quill Forward/Reverse Confirmation Device		○	○
Tail Stock Foot Switch		○	○
<b>Coolant &amp; Air Blow</b>			
Standard Coolant (Nozzle)		●	●
Chuck Coolant (Upper Chuck)		○	○
Gun Coolant		○	○
Through Spindle Coolant (Only for Special Chuck)		☆	☆
Thru Coolant for Live Tool		-	☆
Chuck Air Blow (Upper Chuck)		○	○
Tail Stock Air Blow (Upper Tail Stock)		○	○
Turret Air Blow		☆	☆
Air Gun		○	○
Through Spindle Air Blow (Only for Special Chuck)		☆	☆
High Pressure Coolant	0.5Bar	●	●
	6Bar	○	○
	20Bar	○	○
Power Coolant System (For Automation)		☆	☆
Coolant Chiller (Only fir Sub Tank, Chip Conveyor)		-	-
<b>Chip Disposal</b>			
Coolant Tank	Side	●	●
	Rear	○	○
Chip Conveyor (Hinge/Scraper)	Front (Right)	○	○
	Rear (Rear)	○	○
Special Chip Conveyor (Drum Filter)		☆	☆
Chip Wagon	Standard (180 ℓ [47.5 gal])	○	○
	Swing (200 ℓ [52.8 gal])	○	○
	Large Swing (290 ℓ [76.6 gal])	○	○
	Large Size (330 ℓ [87.2 gal])	○	○
	Customized	☆	☆

● : Standard ○ : Option ☆ : Prior Consultation - : Non Applicable

Safety Device		HD2600	HD2600M
Total Splash Guard		●	●
<b>Electric Device</b>			
Call Light	1Color : ●	●	●
Call Light & Buzzer	3Color : ●●● B	○	○
Electric Cabinet Light		○	○
Remote MPG		-	-
Work Counter	Digital	○	○
Total Counter	Digital	○	○
Tool Counter	Digital	○	○
Multi Tool Counter	Digital	○	○
Electric Circuit Breaker		○	○
AVR (Auto Voltage Regulator)		☆	☆
Transformer	30kVA	○	○
Auto Power Off		○	○
<b>Measurement</b>			
Manual Q-Setter		○	○
Manual Q-Setter (Renishaw)		○	○
Automatic Q-Setter (Renishaw)		○	○
Work Close Confirmation Device	TACO	☆	☆
(Only for Special Chuck)	SMC	☆	☆
Auto Tool Measuring Device		☆	☆
Linear Scale	X Axis	○	○
	Z Axis	○	○
Coolant Level Sensor (Only for Chip Conveyor, bladder Type)		☆	☆
<b>Environment</b>			
Air Conditioner		○	○
Oil Mist Collector		☆	☆
Oil Skimmer (Only for Chip Conveyor)		○	○
MQL (Minimal Quantity Lubrication)		☆	☆
<b>Fixture &amp; Automation</b>			
Auto Door		○	○
Auto Shutter (Only for Automatic System)		☆	☆
Sub Operation Pannel		☆	☆
Bar Feeder Interface		○	○
Bar Feeder (FEDEK)		☆	☆
workpusher (Spring type)		○	○
Extra M-Code 4ea		○	○
Automation Interface		☆	☆
I/O Extension (IN & OUT)	16 Contact	○	○
	32 Contact	○	○
Parts Catcher	Main SP.	○	○
Turret Work Pusher (For Automation)		☆	☆
Parts Conveyor (Required Main Parts Catcher)		☆	☆
Semi Automation System		☆	☆
<b>Hyd. Device</b>			
Standard Hyd. Cylinder	Hollow	●	●
Standard Hyd. Unit	35bar/24 ℓ (6.3gal)	●	●
<b>S/W</b>			
DFC software (HW-eDPC)		○	○
Machine Monitoring System (HW-MMS Cloud/Edge/Remote)		○	○
Machine Monitoring System & Analysis (HW-MMS Edge Plus)		☆	☆
Automation CAM program (HW-ACAM)		○	-
Conversational program (HW-DPRO)		○	○
SmartGuide-i : FANUC		●	●
Thermal Displacement Compensation (HW-TDC)		○	○
Tool Monitoring (HW-TM) : FANUC		○	○
Machine Guidance (HW-MCG) : FANUC		●	●
Energy Saving System (HW-ESS) : FANUC		●	●
Premium Tool Operation : FANUC		●	●
Manual Viewer : FANUC		●	●
Scheduling : FANUC		●	●
Operation Memo : FANUC		●	●
<b>ETC</b>			
Tool Box		●	●
Customized Color	Need Munsel No.	☆	☆
CAD & CAM		☆	☆

❖ 4 channel of TDC(Thermal Displacement Compensation) device is recommended, when more than 6 bar of high pressure coolant is applied, for the high quality machining.

Specifications are subject to change without notice for improvement.

# SPECIFICATIONS

## Standard & Optional

Spindle		HD3100A	HD3100MA
Main Spindle	10"	●	●
Hollow Chuck 3 Jaw	12"	○	○
Main Spindle	10"	○	○
Solid Chuck 3 Jaw	12"	-	-
Belt Type		●	●
Gear Type		-	-
Standard Soft Jaw (1set)		●	●
Chuck Clamp Foot Switch		●	●
2 Steps Hyd. Pressure Device		○	○
Spindle Inside Stopper		☆	☆
5° Index		-	-
Cs-Axis (0.001°)		-	●
Chuck Open/Close Confirmation Device		●	●
2 Steps Chuck Foot Switch		○	○
<b>Turret</b>			
Tool Holder		●	●
Mill Turret	BMT	-	-
Straight Milling Head (Axial)	Collet Type,2ea	-	●
Angular Milling Head (Radial)	Collet Type,2ea	-	●
Straight Milling Head (Axial)	Adapter Type	-	-
Angular Milling Head (Radial)	Adapter Type	-	-
Boring Sleeve		●	●
Drill Socket		○	○
U-Drill Holder		●	●
O.D Extension Holder	For Out-Dia	●	-
Angle Head		-	-
<b>Tail Stock &amp; Steady Rest</b>			
Quill Type Tail Stock	MT#4	-	-
	MT#5	●	●
Built-in Tail Stock	MT#4	○	○
Programable Tail Stock		○	○
Manual Type Hyd. Steady Rest		-	-
Standard Live Center		●	●
High Precession Live Center		☆	☆
2 Steps Tail Stock Pressure System		○	○
Quill Forward/Reverse Confirmation Device		○	○
Tail Stock Foot Switch		○	○
<b>Coolant &amp; Air Blow</b>			
Standard Coolant (Nozzle)		●	●
Chuck Coolant (Upper Chuck)		○	○
Gun Coolant		○	○
Through Spindle Coolant (Only for Special Chuck)		☆	☆
Thru Coolant for Live Tool		-	☆
Chuck Air Blow (Upper Chuck)		○	○
Tail Stock Air Blow (Upper Tail Stock)		○	○
Turret Air Blow		☆	☆
Air Gun		○	○
Through Spindle Air Blow (Only for Special Chuck)		☆	☆
High Pressure Coolant	0.5Bar	●	●
	6Bar	○	○
	20Bar	○	○
Power Coolant System (For Automation)		☆	☆
Coolant Chiller (Only for Sub Tank, Chip Conveyor)		-	-
<b>Chip Disposal</b>			
Coolant Tank	Side	●	●
	Rear	○	○
Chip Conveyor (Hinge/Scraper)	Front (Right)	○	○
	Rear (Rear)	○	○
Special Chip Conveyor (Drum Filter)		☆	☆
Chip Wagon	Standard (180 ℓ [47.5 gal])	○	○
	Swing (200 ℓ [52.8 gal])	○	○
	Large Swing (290 ℓ [76.6 gal])	○	○
	Large Size (330 ℓ [87.2 gal])	○	○
	Customized	☆	☆

● : Standard ○ : Option ☆ : Prior Consultation - : Non Applicable

Safety Device		HD3100A	HD3100MA
Total Splash Guard		●	●
<b>Electric Device</b>			
Call Light	1Color : ●	●	●
Call Light & Buzzer	3Color : ● ● ● B	○	○
Electric Cabinet Light		○	○
Remote MPG		-	-
Work Counter	Digital	○	○
Total Counter	Digital	○	○
Tool Counter	Digital	○	○
Multi Tool Counter	Digital	○	○
Electric Circuit Breaker		○	○
AVR (Auto Voltage Regulator)		☆	☆
Transformer	30kVA	○	○
Auto Power Off		○	○
<b>Measurement</b>			
Manual Q-Setter		○	○
Manual Q-Setter (Renishaw)		○	○
Automatic Q-Setter (Renishaw)		○	○
Work Close Confirmation Device	TACO	☆	☆
(Only for Special Chuck)	SMC	☆	☆
Auto Tool Measuring Device		☆	☆
Linear Scale	X Axis	○	○
	Z Axis	○	○
Coolant Level Sensor (Only for Chip Conveyor, bladder Type)		☆	☆
<b>Environment</b>			
Air Conditioner		○	○
Oil Mist Collector		☆	☆
Oil Skimmer (Only for Chip Conveyor)		○	○
MQL (Minimal Quantity Lubrication)		☆	☆
<b>Fixture &amp; Automation</b>			
Auto Door		○	○
Auto Shutter (Only for Automatic System)		☆	☆
Sub Operation Pannel		☆	☆
Bar Feeder Interface		○	○
Bar Feeder (FEDEK)		☆	☆
workpusher (Spring type)		○	○
Extra M-Code 4ea		○	○
Automation Interface		☆	☆
I/O Extension (IN & OUT)	16 Contact	○	○
	32 Contact	○	○
Parts Catcher	Main SP.	○	○
Turret Work Pusher (For Automation)		☆	☆
Parts Conveyor (Required Main Parts Catcher)		☆	☆
Semi Automation System		☆	☆
<b>Hyd. Device</b>			
Standard Hyd. Cylinder	Hollow	●	●
Standard Hyd. Unit	35bar/30 ℓ (7.9gal)	●	●
<b>S/W</b>			
DNC software (HW-eDNC)		○	○
Machine Monitoring System (HW-MMS Cloud/Edge/Remote)		○	○
Machine Monitoring System & Analysis (HW-MMS Edge Plus)		☆	☆
Automation CAM program (HW-ACAM)		○	-
Conversational program (HW-DPRO)		○	○
SmartGuide-i : FANUC		●	●
Thermal Displacement Compensation (HW-TDC)		○	○
Tool Monitoring (HW-TM) : FANUC		○	○
Machine Guidance (HW-MCG) : FANUC		●	●
Energy Saving System (HW-ESS) : FANUC		●	●
Premium Tool Operation : FANUC		●	●
Manual Viewer : FANUC		●	●
Scheduling : FANUC		●	●
Operation Memo : FANUC		●	●
<b>ETC</b>			
Tool Box		●	●
Customized Color	Need Munsell No.	☆	☆
CAD & CAM		☆	☆

◆ 4 channel of TDC(Thermal Displacement Compensation) device is recommended, when more than 6 bar of high pressure coolant is applied, for the high quality machining.  
Specifications are subject to change without notice for improvement.

# SPECIFICATIONS

## Standard & Optional

Spindle		HD3100/L	HD3100M/LM
Main Spindle	12"	●	●
Hollow Chuck 3 Jaw	15"	-	-
Main Spindle	12"	-	-
Solid Chuck 3 Jaw	15"	-	-
Belt Type		●	●
Gear Type		○	-
Standard Soft Jaw (1set)		●	●
Chuck Clamp Foot Switch		●	●
2 Steps Hyd. Pressure Device		○	○
Spindle Inside Stopper		☆	☆
5" Index		☆	☆
Cs-Axis (0.001")		-	●
Chuck Open/Close Confirmation Device		●	●
2 Steps Chuck Foot Switch		○	○
<b>Turret</b>			
Tool Holder		●	●
Mill Turret	BMT	-	●
Straight Milling Head (Axial)	Collet Type,2ea	-	●
Angular Milling Head (Radial)	Collet Type,2ea	-	●
Straight Milling Head (Axial)	Adapter Type	-	-
Angular Milling Head (Radial)	Adapter Type	-	-
Boring Sleeve		●	●
Drill Socket		○	○
U-Drill Holder		●	●
O.D Extension Holder	For Out-Dia	●	-
Angle Head		-	-
<b>Tail Stock &amp; Steady Rest</b>			
Quill Type Tail Stock	MT#4	-	-
	MT#5	●	●
Built-in Tail Stock	MT#4	○	○
Programmable Tail Stock		○	○
Manual Type Hyd. Steady Rest		-	-
Standard Live Center		●	●
High Precision Live Center		☆	☆
2 Steps Tail Stock Pressure System		○	○
Quill Forward/Reverse Confirmation Device		○	○
Tail Stock Foot Switch		○	○
<b>Coolant &amp; Air Blow</b>			
Standard Coolant (Nozzle)		●	●
Chuck Coolant (Upper Chuck)		○	○
Gun Coolant		○	○
Through Spindle Coolant (Only for Special Chuck)		☆	☆
Thru Coolant for Live Tool		-	☆
Chuck Air Blow (Upper Chuck)		○	○
Tail Stock Air Blow (Upper Tail Stock)		○	○
Turret Air Blow		☆	☆
Air Gun		○	○
Through Spindle Air Blow (Only for Special Chuck)		☆	☆
High Pressure Coolant	0.5Bar	●	●
	6Bar	○	○
	20Bar	○	○
Power Coolant System (For Automation)		☆	☆
Coolant Chiller (Only for Sub Tank, Chip Conveyor)		-	-
<b>Chip Disposal</b>			
Coolant Tank	Side	●	●
	Rear	○/-	○/-
Chip Conveyor (Hinge/Scraper)	Front (Right)	○	○
	Rear (Rear)	○/-	○/-
Special Chip Conveyor (Drum Filter)		☆	☆
Chip Wagon	Standard (180 ℓ [47.5 gal])	○	○
	Swing (200 ℓ [52.8 gal])	○	○
	Large Swing (290 ℓ [76.6 gal])	○	○
	Large Size (330 ℓ [87.2 gal])	○	○
	Customized	☆	☆

● : Standard ○ : Option ☆ : Prior Consultation - : Non Applicable

Safety Device		HD3100/L	HD3100M/LM
Total Splash Guard		●	●
<b>Electric Device</b>			
Call Light	1Color : ●	●	●
Call Light & Buzzer	3Color : ● ■ ■ B	○	○
Electric Cabinet Light		○	○
Remote MPG		-	-
Work Counter	Digital	○	○
Total Counter	Digital	○	○
Tool Counter	Digital	○	○
Multi Tool Counter	Digital	○	○
Electric Circuit Breaker		○	○
AVR (Auto Voltage Regulator)		☆	☆
Transformer	30kVA (Belt)	○	○
	35kVA (Gear)	○	○
Auto Power Off		○	○
<b>Measurement</b>			
Manual Q-Setter		○	○
Manual Q-Setter (Renishaw)		○	○
Automatic Q-Setter (Renishaw)		○	○
Work Close Confirmation Device (Only for Special Chuck)	TACO	☆	☆
	SMC	☆	☆
Auto Tool Measuring Device		☆	☆
Linear Scale	X Axis	○	○
	Z Axis	○	○
Coolant Level Sensor (Only for Chip Conveyor, bladder Type)		☆	☆
<b>Environment</b>			
Air Conditioner		○	○
Oil Mist Collector		☆	☆
Oil Skimmer (Only for Chip Conveyor)		○	○
MQL (Minimal Quantity Lubrication)		☆	☆
<b>Fixture &amp; Automation</b>			
Auto Door		○	○
Auto Shutter (Only for Automatic System)		☆	☆
Sub Operation Pannel		☆	☆
Bar Feeder Interface		○	○
Bar Feeder (FEDEK)		☆	☆
workpusher (Spring type)		○	○
Extra M-Code 4ea		○	○
Automation Interface		☆	☆
I/O Extension (IN & OUT)	16 Contact	○	○
	32 Contact	○	○
Parts Catcher	Main SP.	○	○
Turret Work Pusher (For Automation)		☆	☆
Parts Conveyor (Required Main Parts Catcher)		☆	☆
Semi Automation System		☆	☆
<b>Hyd. Device</b>			
Standard Hyd. Cylinder	Hollow	●	●
Standard Hyd. Unit	35bar/30 ℓ (7.9gal)	●	●
<b>S/W</b>			
DNC software (HW-eDNC)		○	○
Machine Monitoring System (HW-MMS Cloud/Edge/Remote)		○	○
Machine Monitoring System & Analysis (HW-MMS Edge Plus)		☆	☆
Automation CAM program (HW-ACAM)		○	-
Conversational program (HW-DPRO)		○	○
SmartGuide-i : FANUC		●	●
Thermal Displacement Compensation (HW-TDC)		○	○
Tool Monitoring (HW-TM) : FANUC		○	○
Machine Guidance (HW-MCG) : FANUC		●	●
Energy Saving System (HW-ESS) : FANUC		●	●
Premium Tool Operation : FANUC		●	●
Manual Viewer : FANUC		●	●
Scheduling : FANUC		●	●
Operation Memo : FANUC		●	●
<b>ETC</b>			
Tool Box		●	●
Customized Color	Need Munsel No.	☆	☆
CAD & CAM		☆	☆

❖ 4 channel of TDC(Thermal Displacement Compensation) device is recommended, when more than 6 bar of high pressure coolant is applied, for the high quality machining.

Specifications are subject to change without notice for improvement.



# SPECIFICATIONS

## Spindle-Turret Output/Torque Diagram (HD2600 Series)

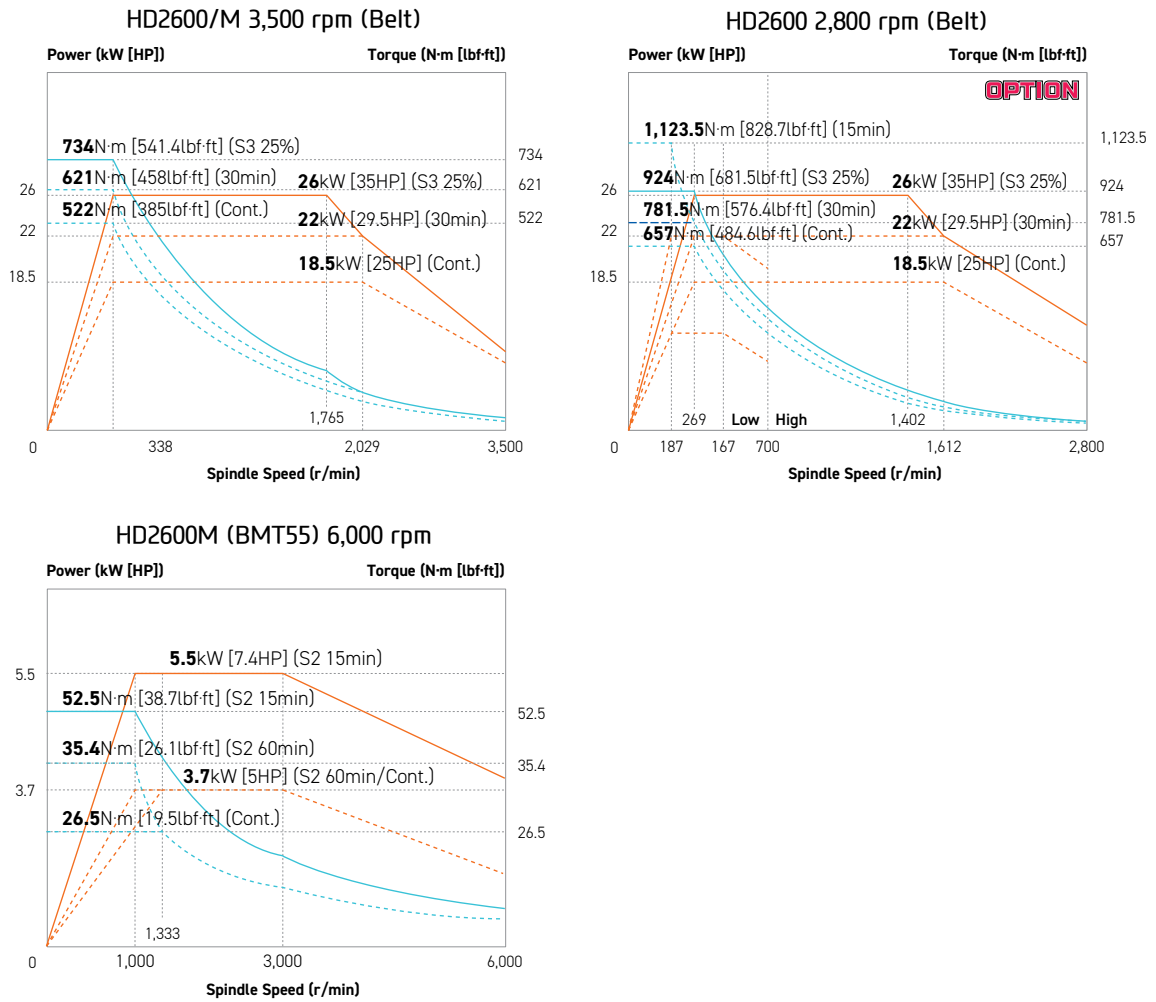

# SPECIFICATIONS

## Spindle-Turret Output/Torque Diagram (HD3100 Series)

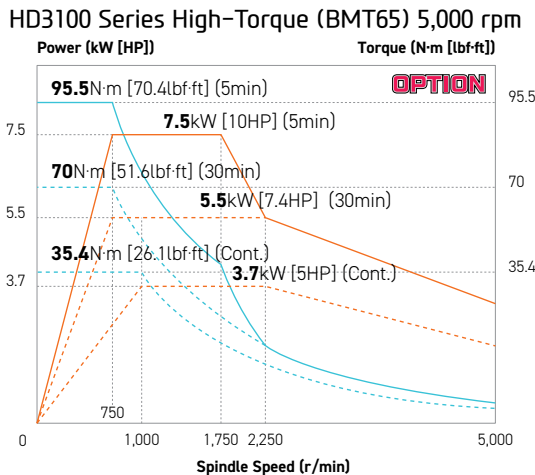
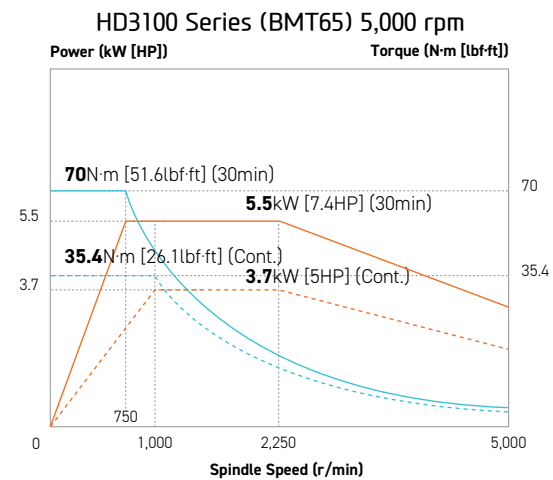
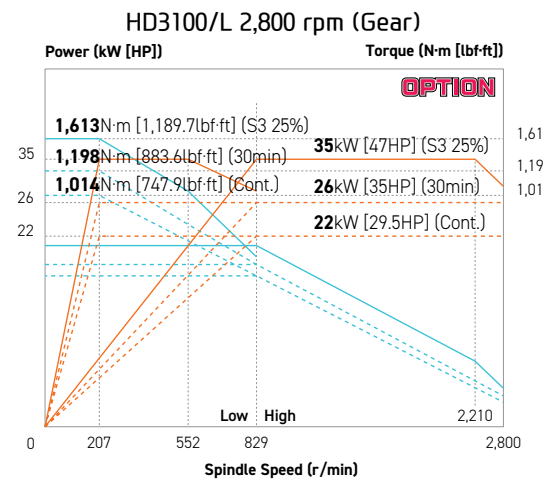
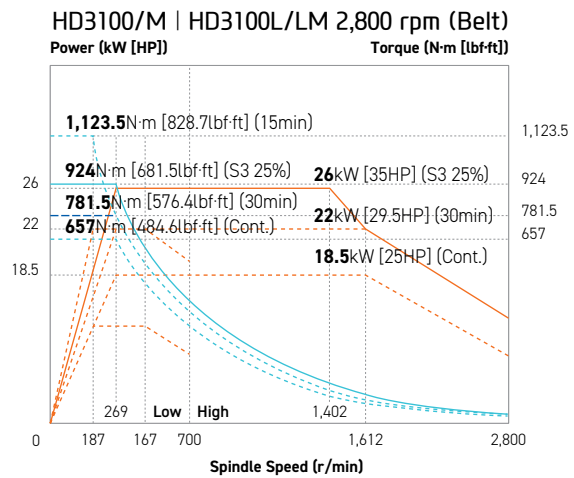
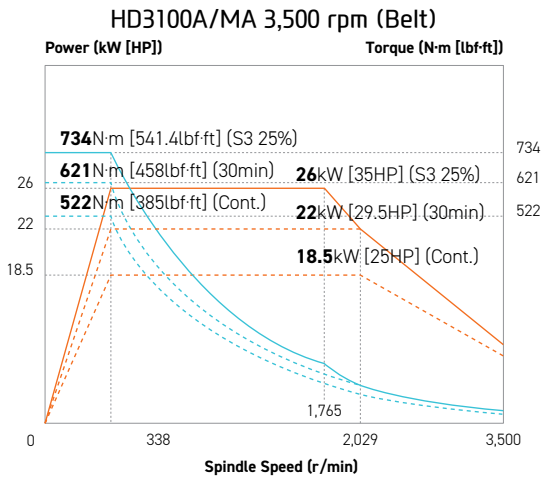

# SPECIFICATIONS

## External Dimensions

unit : mm(in)

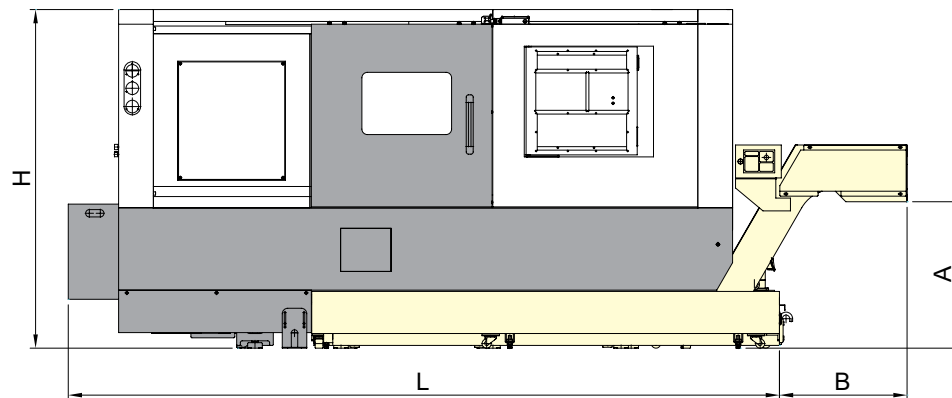
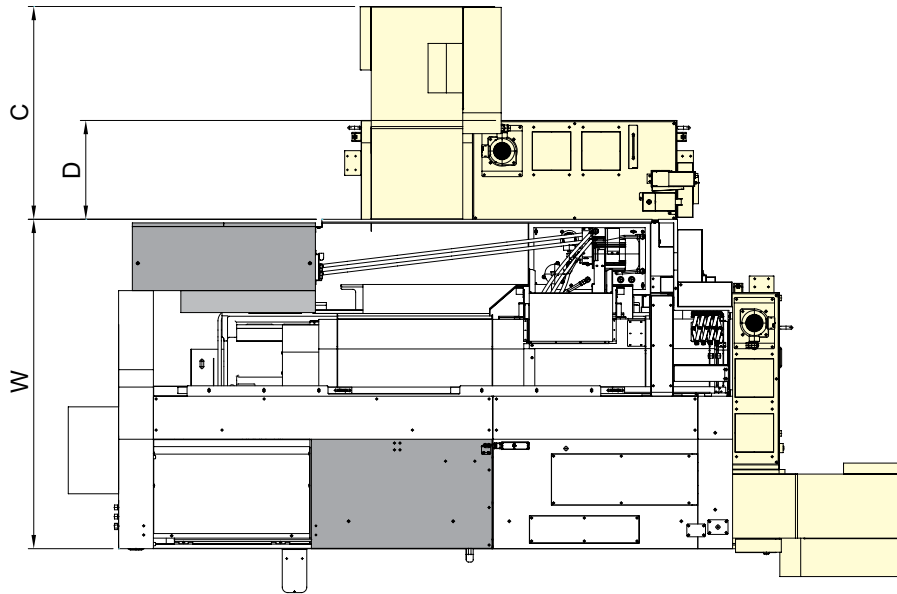

Dimension		HD2600	HD2600M	HD3100A	HD3100MA	HD3100	HD3100M	HD3100L	HD3100LM
Length	L	3,400 (133.9")			3,885 (153")			4,405 (173.4")	
Length (Gear Spindle Opt.)		-			4,045 (159.2")			4,565 (179.7")	
Width	W	1,708 (67.2")		1,800 (70.9")			1,978 (77.9")		
Height	H	1,755 (69.1")			1,850 (72.8")				
Conveyor height	A	1,200 (47.2") or 850 (33.5") [Opt.]							
Side type chip conveyor	B	1,120 (44.1")			900 (35.4")			980 (38.6")	
Rear type chip conveyor	C	1,210 (47.6")			1,120 (44.1")			-	
Rear tank	D	630 (24.8")			540 (21.3")			-	

# SPECIFICATIONS

## Interference

unit : mm(in)

(10 Station)  
HD2600

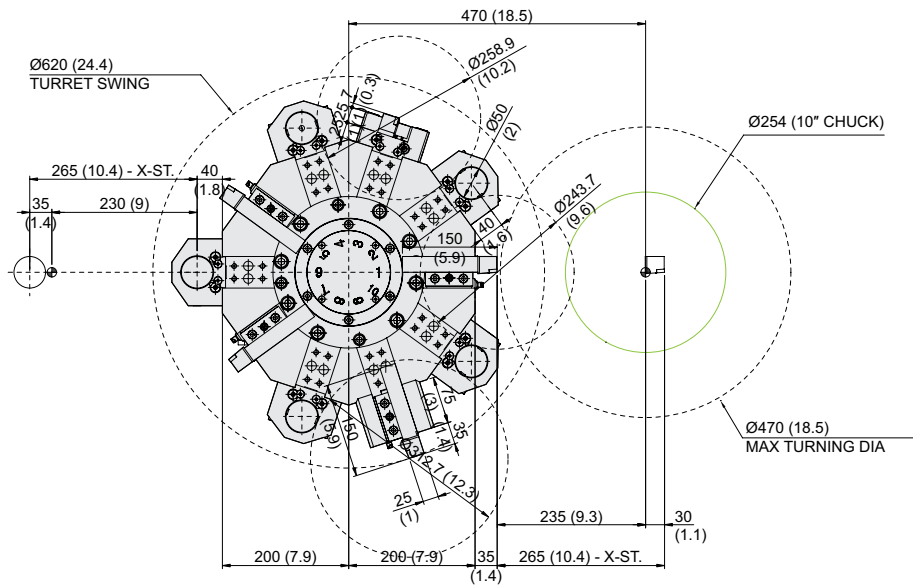

HD2600M

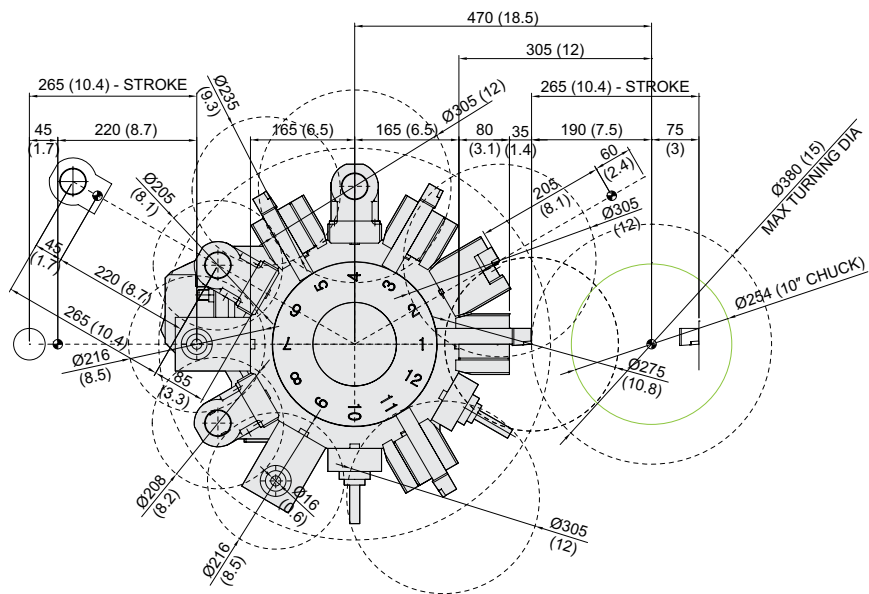

If the tool is positioned differently than the above tooling drawings, the application of the OD Extension holder may interfere with the chuck.

# SPECIFICATIONS

## Interference

unit : mm(in)

(10 Station)  
HD3100A  
HD3100/L

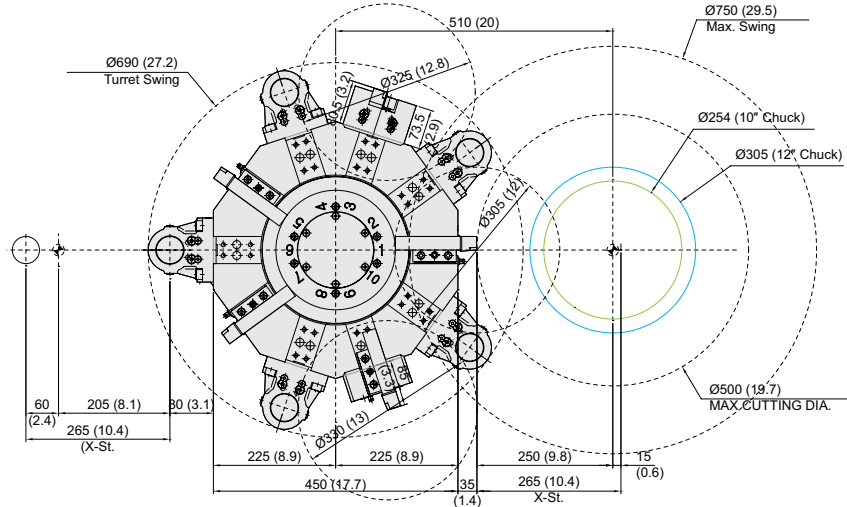

(12 Station)  
HD3100A  
HD3100/L

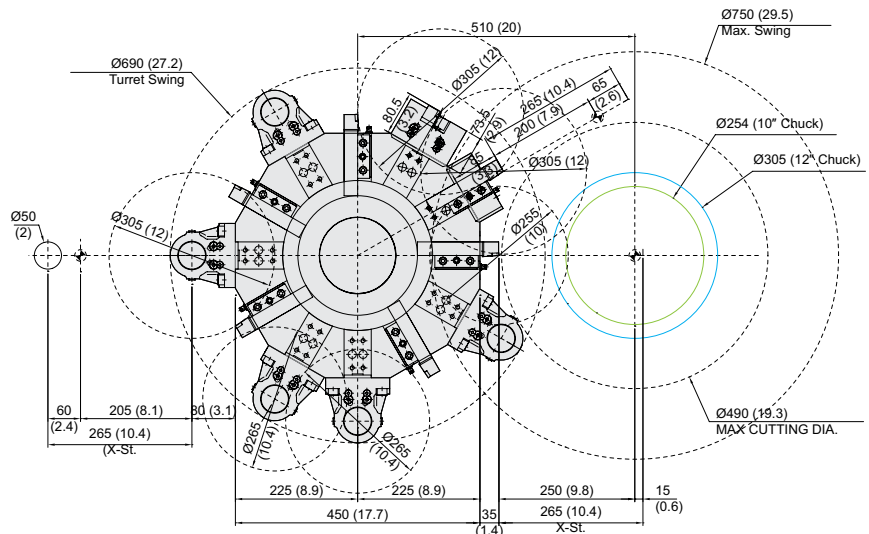

HD3100MA  
HD3100M/LM

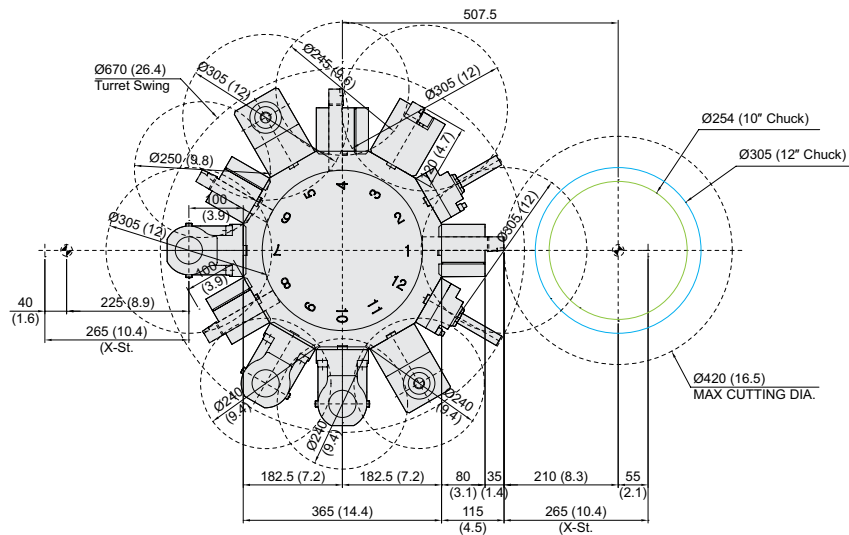

If the tool is positioned differently than the above tooling drawings, the application of the OD Extension holder may interfere with the chuck.

# SPECIFICATIONS

## Tooling System

unit : mm(in)

□ Option

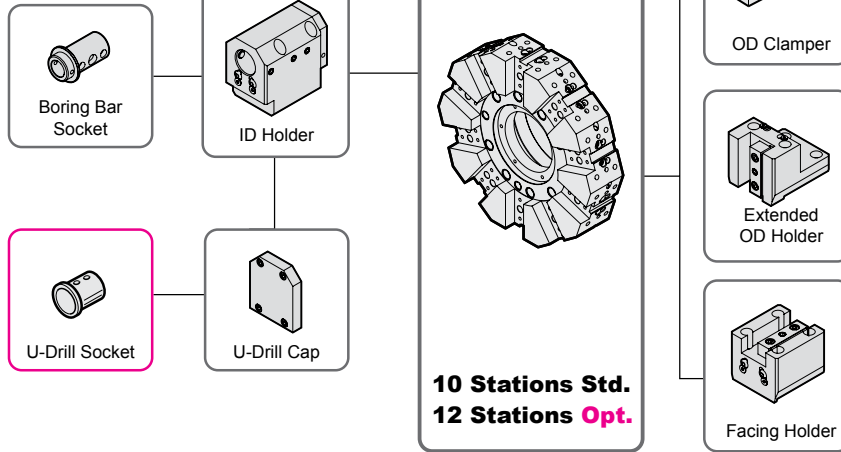

## Tooling Parts Detail

ITEM			HD2600		HD3100A		HD3100		HD3100L	
			mm Unit	inch Unit	mm Unit	inch Unit	mm Unit	inch Unit	mm Unit	inch Unit
Turning Holder	O.D Holder	Right/Left	-	-	-	-	-	-	-	-
		Extension	1	1	1	1	1	1	1	1
	Facing Holder		1	1	1	1	1	1	1	1
Boring Holder	I.D Holder	Single	5	5	5	5	5	5	5	5
	U-Drill Holder	Cap	1	1	1	1	1	1	1	1
Driven Holder	Straight Mill Holder	Standard	-	-	-	-	-	-	-	-
		TTC	-	-	-	-	-	-	-	-
	Angular Mill Holder	Standard	-	-	-	-	-	-	-	-
		TTC	-	-	-	-	-	-	-	-
Socket	Boring	Ø12 (Ø1/2")	1	1	1	1	1	1	1	1
		Ø16 (Ø5/8")	1	1	1	1	1	1	1	1
		Ø20 (Ø3/4")	1	1	1	1	1	1	1	1
		Ø25 (Ø1")	1	1	1	1	1	1	1	1
		Ø32 (Ø1 1/4")	1	1	1	1	1	1	1	1
		Ø40 (Ø1 1/2")	1	1	1	1	1	1	1	1
	Drill	MT 1 x MT 2	Opt.	Opt.	Opt.	Opt.	Opt.	Opt.	Opt.	Opt.
		MT 2	Opt.	Opt.	Opt.	Opt.	Opt.	Opt.	Opt.	Opt.
		MT 3	Opt.	Opt.	Opt.	Opt.	Opt.	Opt.	Opt.	Opt.
		MT 4	Opt.	Opt.	Opt.	Opt.	Opt.	Opt.	Opt.	Opt.
	ER Collet		-	-	-	-	-	-	-	-

# SPECIFICATIONS

## Tooling System

unit : mm(in)

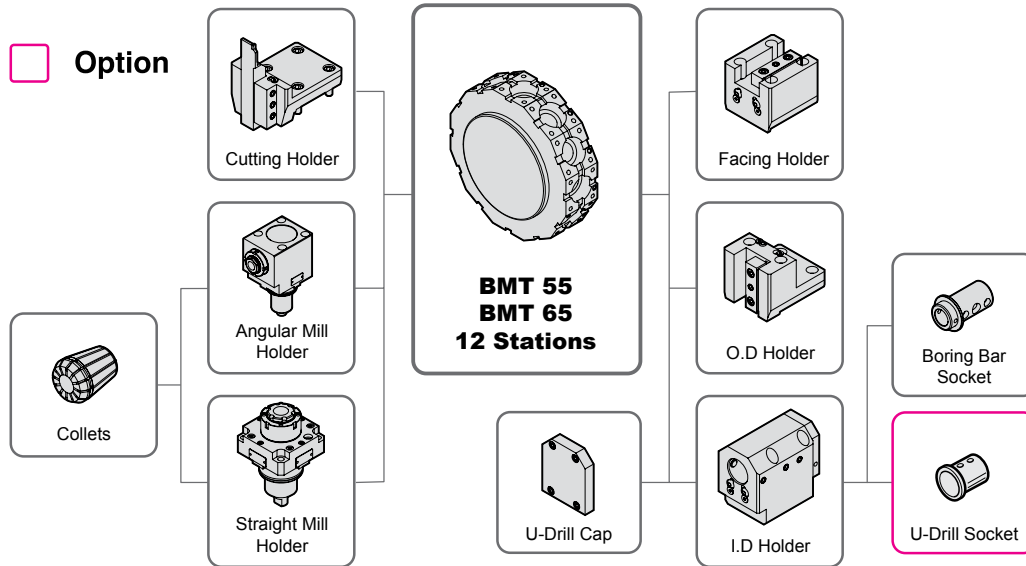

## Tooling Parts Detail

ITEM			HD2600M		HD3100MA		HD3100M		HD3100LM	
			mm Unit	inch Unit	mm Unit	inch Unit	mm Unit	inch Unit	mm Unit	inch Unit
Turning Holder	O.D Holder	Right/Left	4	4	4	4	4	4	4	4
	Cutting Holder		-	-	-	-	-	-	-	-
	Facing Holder		1	1	1	1	1	1	1	1
Boring Holder	I.D Holder	Single	3	3	3	3	3	3	3	3
	U-Drill	Cap	1	1	1	1	1	1	1	1
Driven Holder	Straight Mill Holder	Standard	2	2	2	2	2	2	2	2
		TTC	-	-	-	-	-	-	-	-
	Angular Mill Holder	Standard	2	2	2	2	2	2	2	2
		TTC	-	-	-	-	-	-	-	-
Socket	Boring	Ø10 (Ø3/8")	1	1	-	-	-	-	-	-
		Ø12 (Ø1/2")	1	1	1	1	1	1	1	1
		Ø16 (Ø5/8")	1	1	1	1	1	1	1	1
		Ø20 (Ø3/4")	1	1	1	1	1	1	1	1
		Ø25 (Ø1")	1	1	1	1	1	1	1	1
		Ø32 (Ø1 1/4")	1	1	1	1	1	1	1	1
		Ø40 (Ø1 1/2")	-	-	1	1	1	1	1	1
	Drill	MT 1 x MT 2	Opt.	Opt.	Opt.	Opt.	Opt.	Opt.	Opt.	Opt.
		MT 2	Opt.	Opt.	Opt.	Opt.	Opt.	Opt.	Opt.	Opt.
		MT 3	Opt.	Opt.	Opt.	Opt.	Opt.	Opt.	Opt.	Opt.
		MT 4	-	-	Opt.	Opt.	Opt.	Opt.	Opt.	Opt.
	ER Collet		1 Set	1 Set	1 Set	1 Set	1 Set	1 Set	1 Set	1 Set
	Adapter Set		Opt.	Opt.	Opt.	Opt.	Opt.	Opt.	Opt.	Opt.

Specifications are subject to change without notice for improvement. (HD3100 Series - I.D. Tool Holder Single/U-drill <Combined Use>)

# SPECIFICATIONS

## Tooling Travel Range

unit : mm(in)

### HD2600

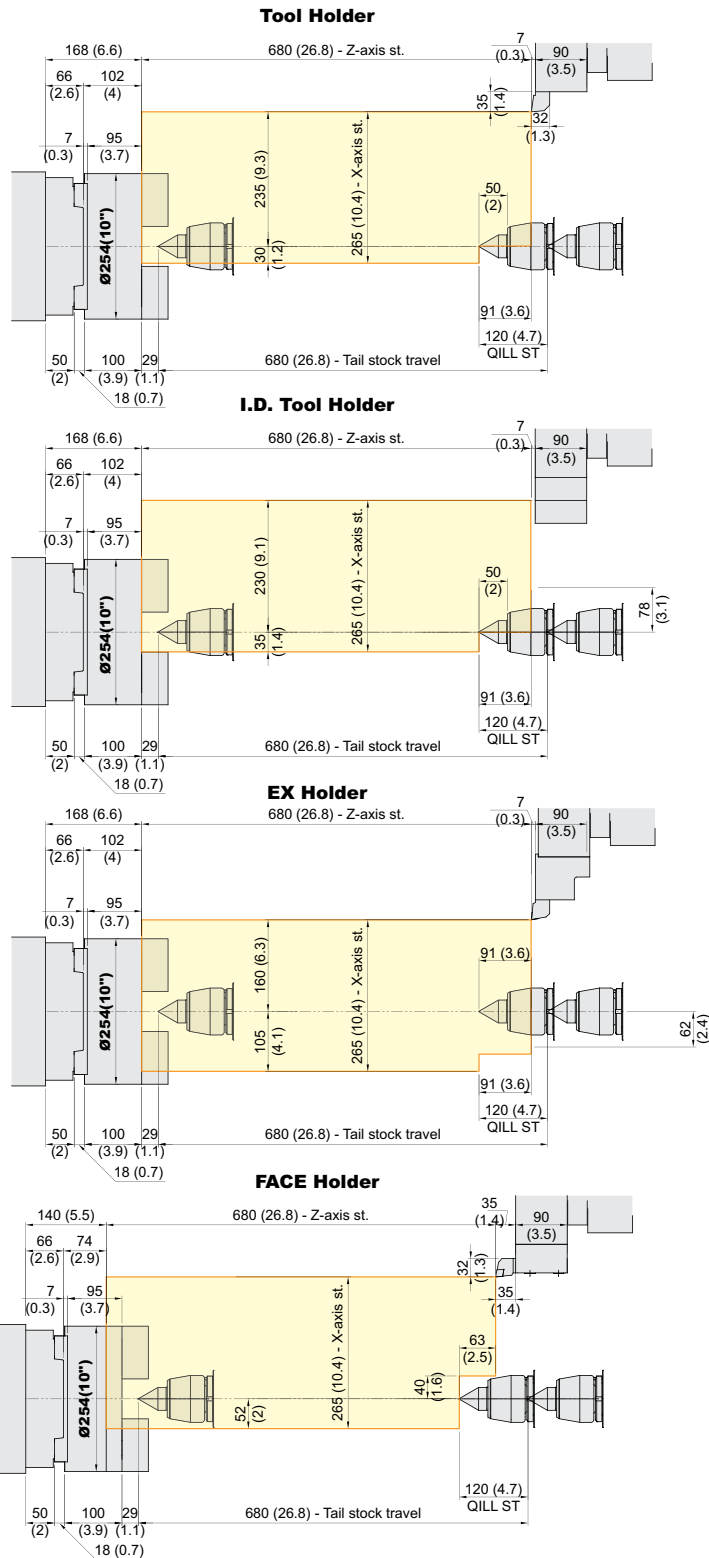



# SPECIFICATIONS

## Tooling Travel Range

unit : mm(in)

### HD2600M

#### O.D. Tool Holder

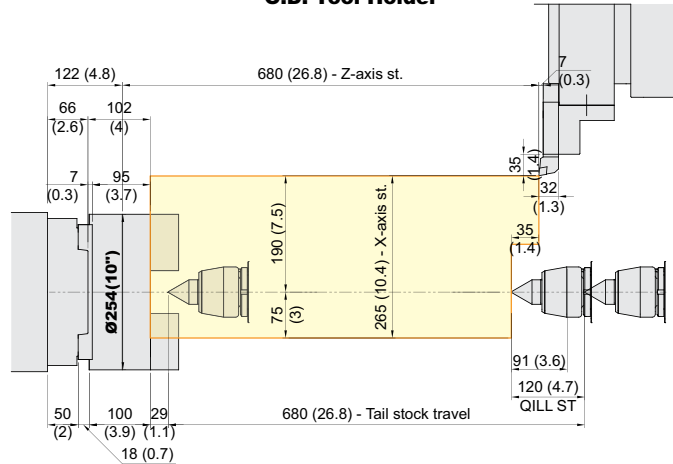

#### I.D. Tool Holder

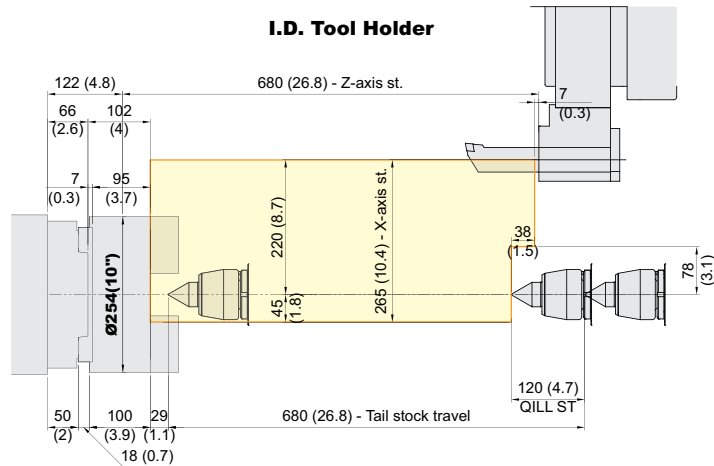

#### Straight Mill Holder

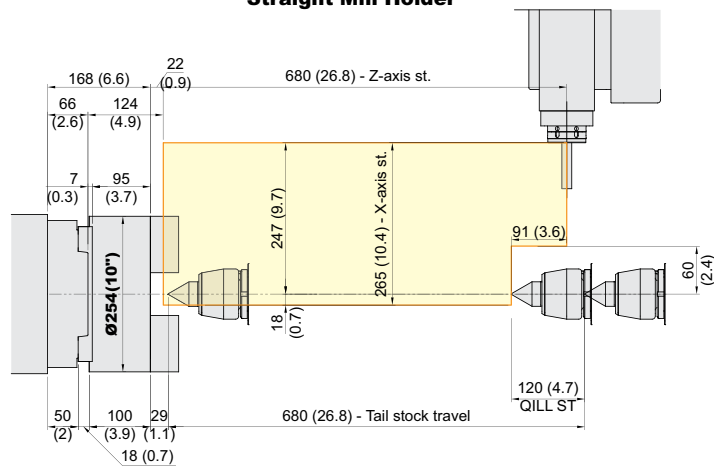

# SPECIFICATIONS

## Tooling Travel Range

unit : mm(in)

### HD2600M

#### FACE Holder

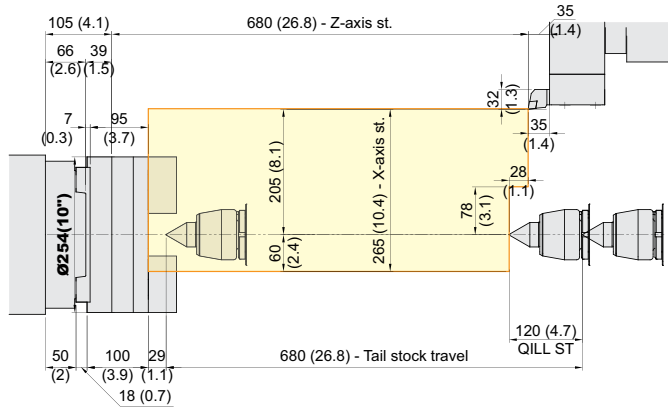

#### Angular Mill Holder

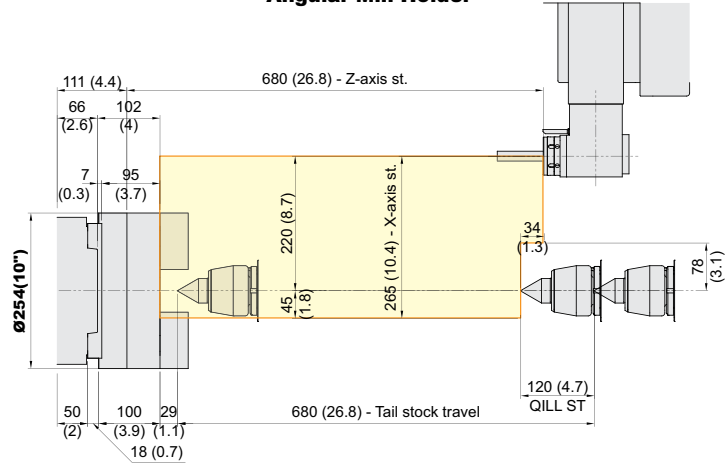

# SPECIFICATIONS

## Tooling Travel Range

unit : mm(in)

### HD3100A | HD3100

#### O.D. Tool Holder

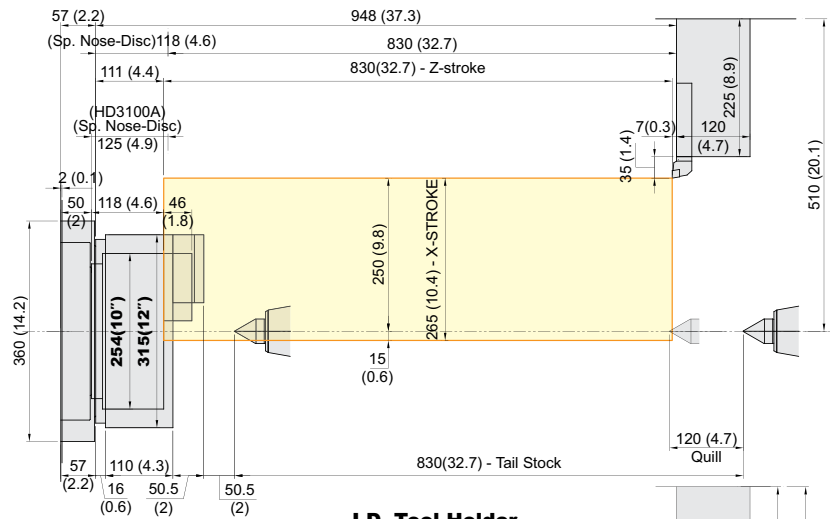

#### I.D. Tool Holder

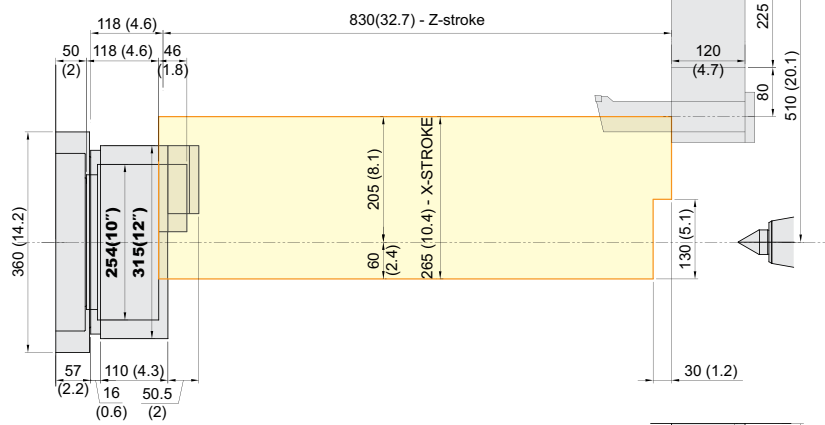

#### Face Tool Holder

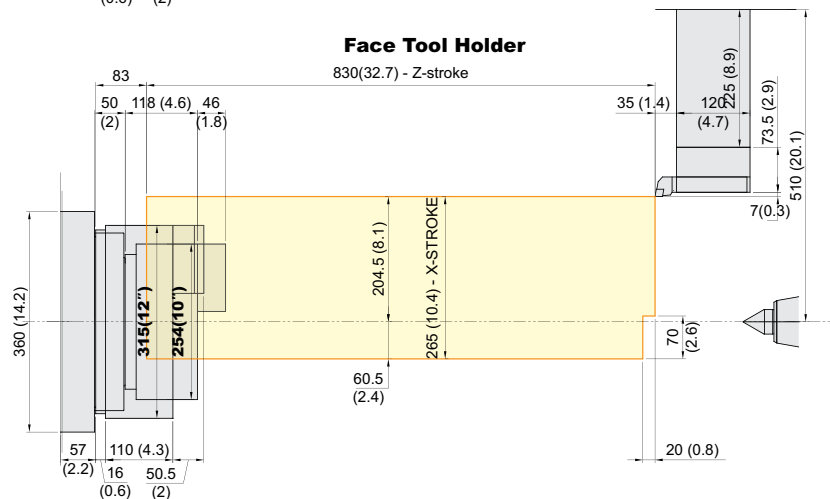

# SPECIFICATIONS

## Tooling Travel Range

unit : mm(in)

### HD3100L

#### O.D. Tool Holder

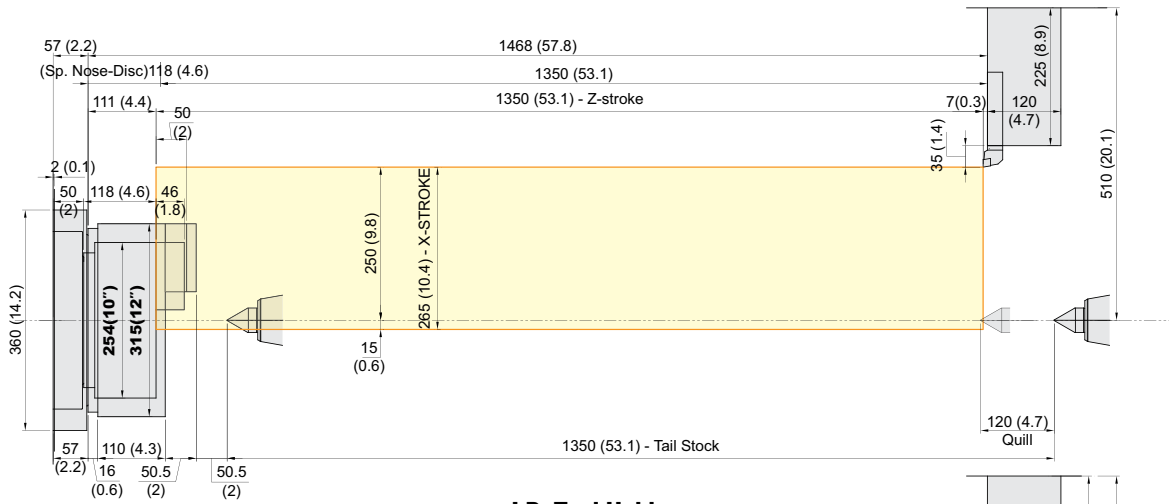

#### I.D. Tool Holder

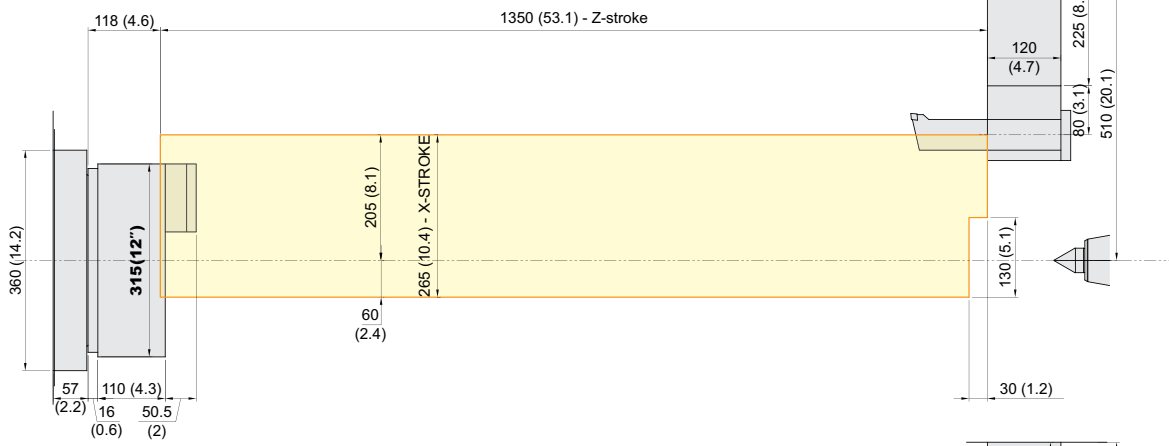

#### Face Tool Holder

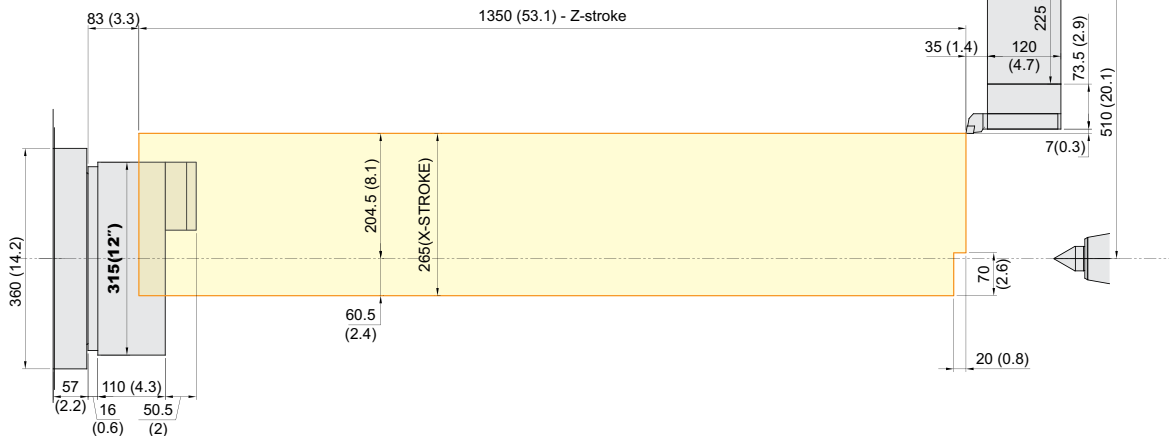

# SPECIFICATIONS

Tooling Travel Range

unit : mm(in)

## HD3100MA | HD3100M

### O.D. Tool Holder

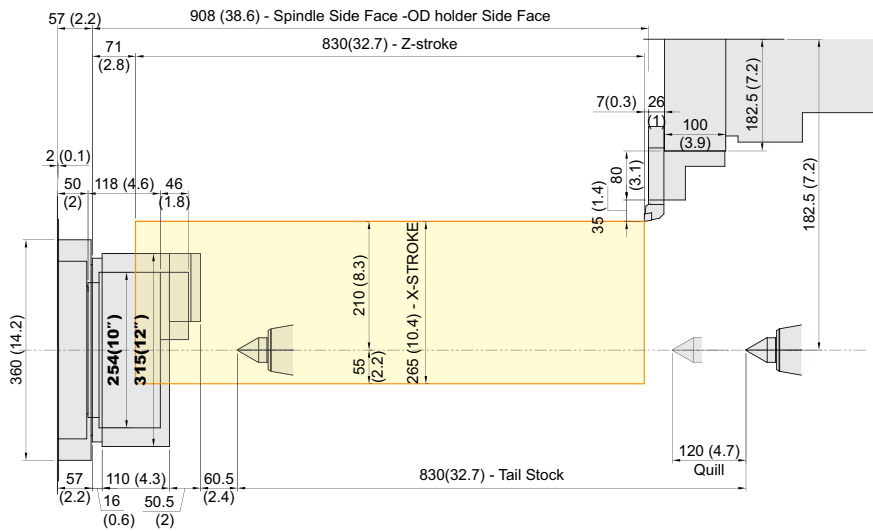

### I.D. Tool Holder

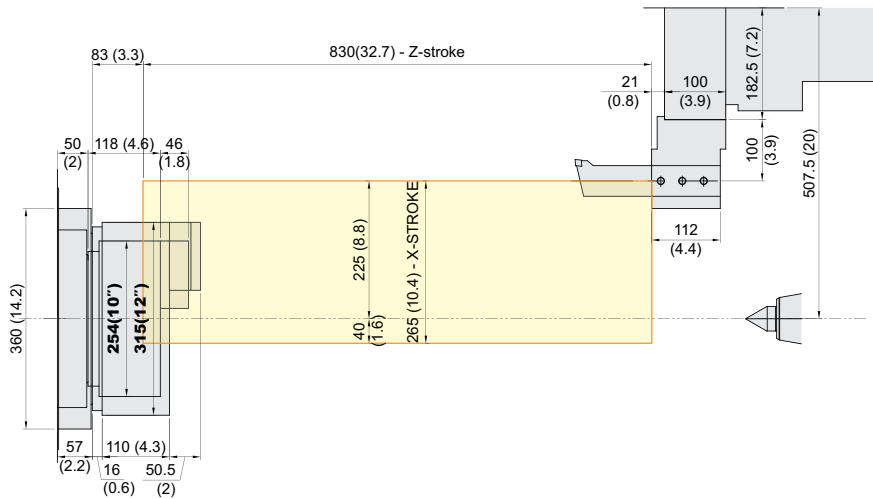

# SPECIFICATIONS

## Tooling Travel Range

unit : mm(in)

### HD3100MA | HD3100M

#### Face Tool Holder

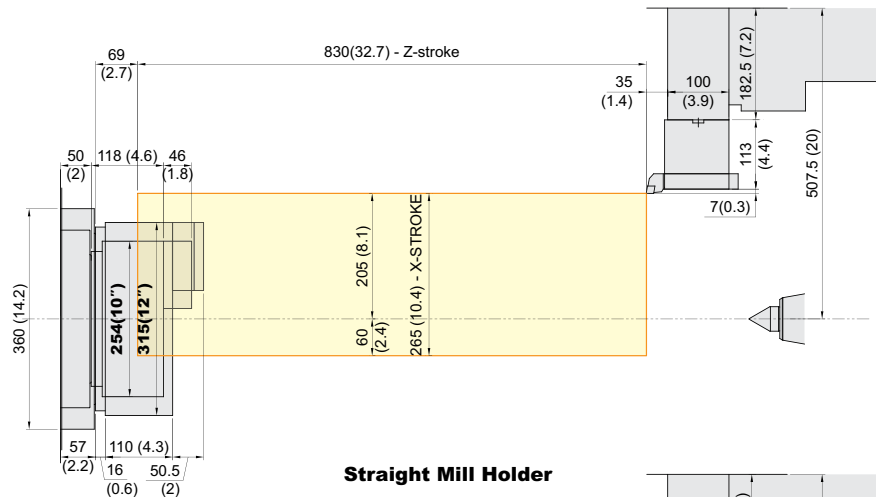

#### Straight Mill Holder

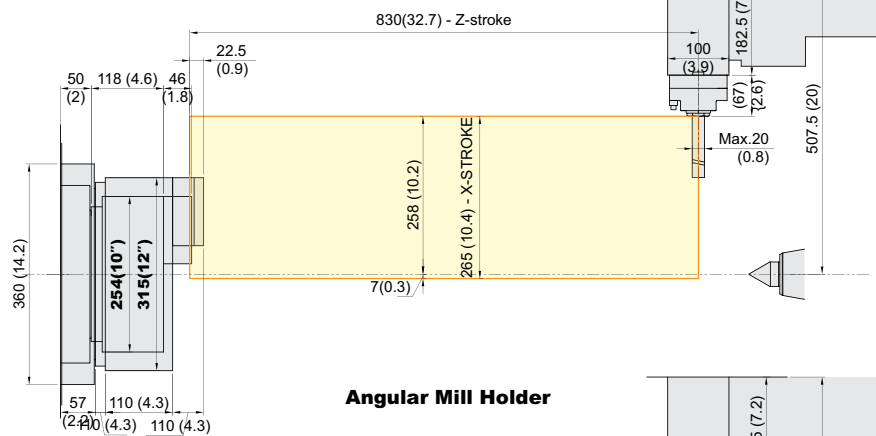

#### Angular Mill Holder

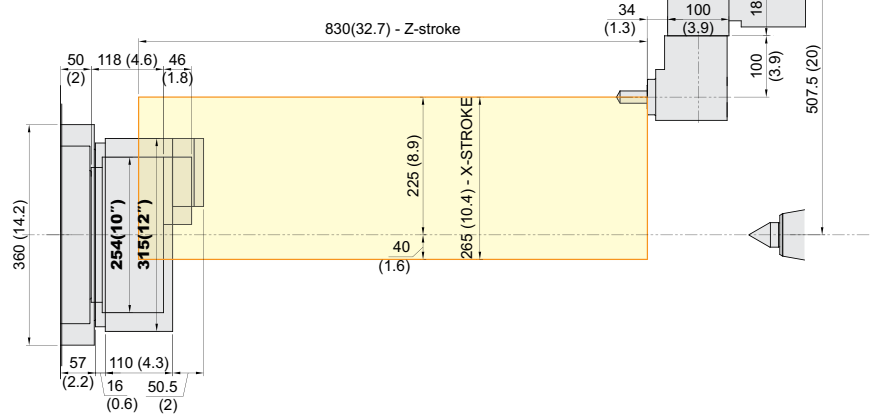

# SPECIFICATIONS

## Tooling Travel Range

unit : mm(in)

### HD3100LM

#### O.D. Tool Holder

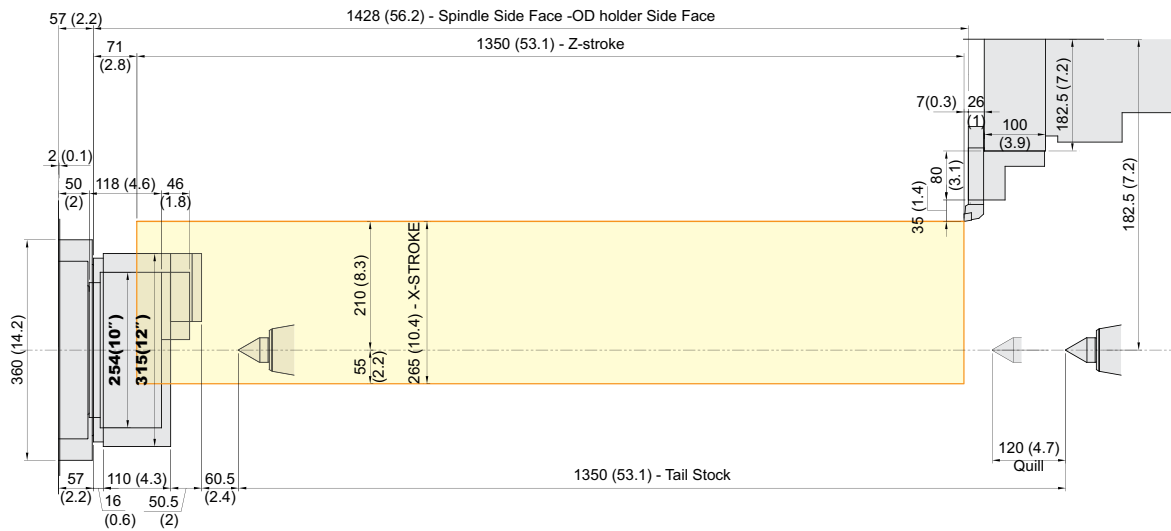

#### I.D. Tool Holder

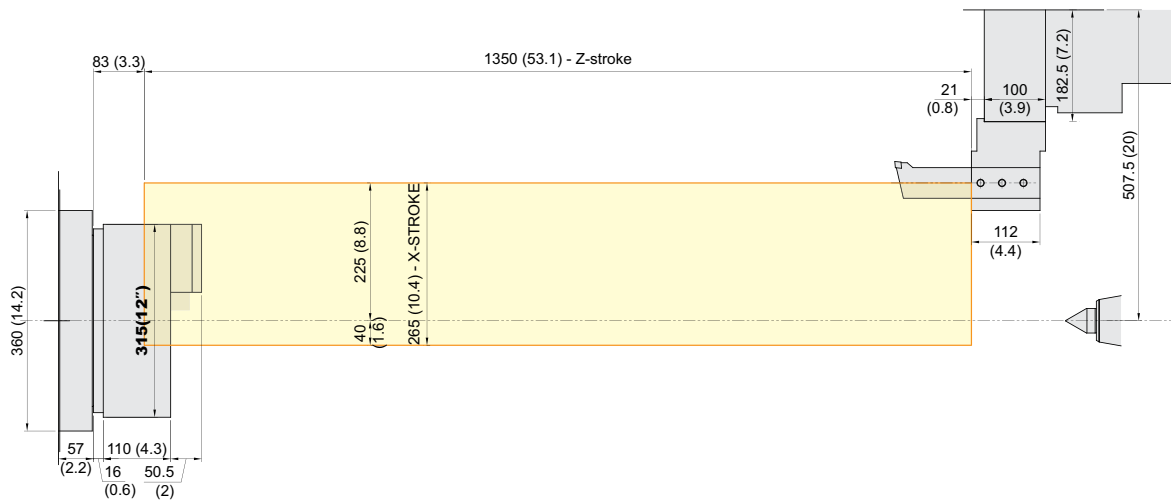

# SPECIFICATIONS

## Tooling Travel Range

unit : mm(in)

### HD3100LM

#### Face Tool Holder

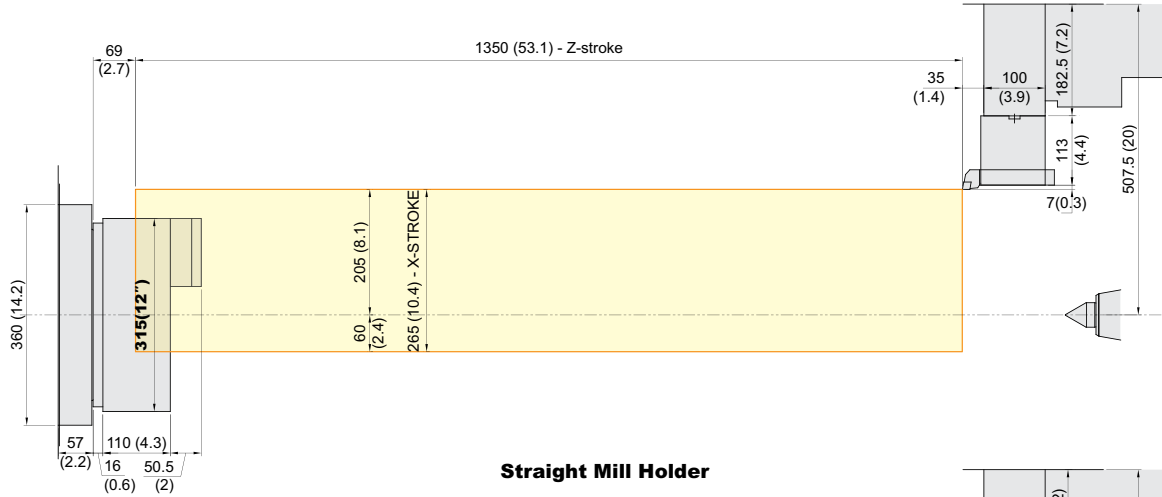

#### Straight Mill Holder

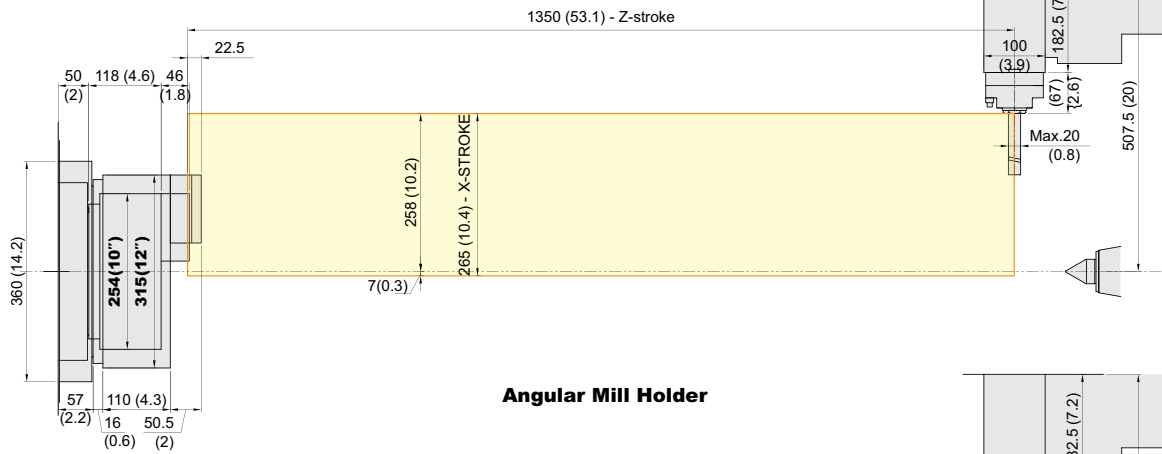

#### Angular Mill Holder

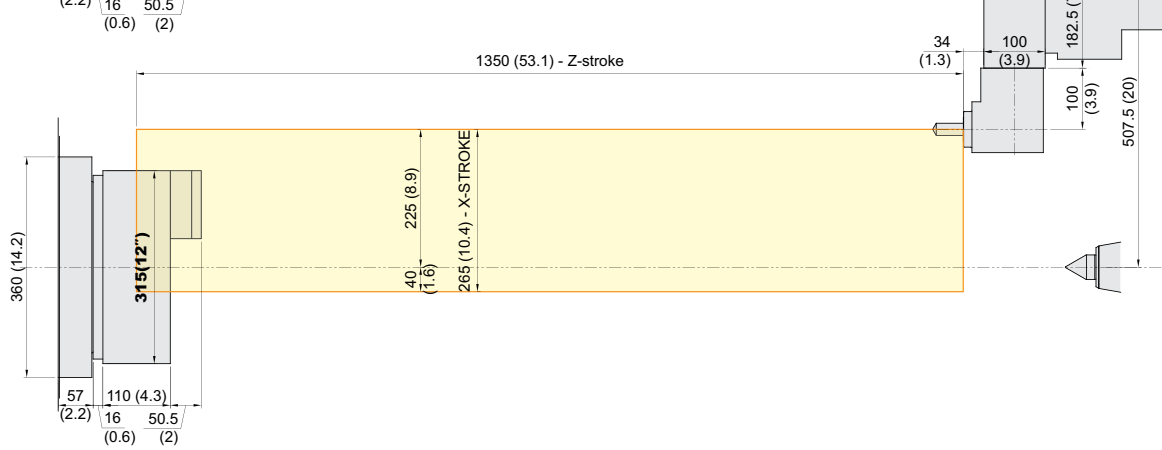



# SPECIFICATIONS

## Specifications

[ ] : Option

MODEL		HD2600	HD2600M	HD3100A	HD3100MA	
CAPACITY	Swing Over the Bed	mm(in)	Ø630 (24.8")		Ø750 (29.5")	
	Swing Over the Carriage	mm(in)	Ø460 (18.1")		Ø500 (19.7")	
	Max. Turning Dia.	mm(in)	Ø460 (18.1")	Ø380 (15")	Ø500 (19.7")	Ø420 (16.5")
	Max. Turning Length	mm(in)	659 (25.9")	613 (24.1")	780 (30.7")	740 (29.1")
	Bar Capacity	mm(in)	Ø81 (3.2")			
SPINDLE	Chuck Size	inch	10" [12"]	10"		
	Spindle Bore	mm(in)	Ø91 (3.6")			
	Spindle Speed (rpm)	r/min	3,500 [2,800]	3,500		
	Motor (Max/Cont.)	kW(HP)	26/18.5 (35/25)			
	Torque (Max/Cont.)	N·m (lbfft)	734/522 (541.4/385) [1,123/657 (828.7/484.6)]	734/522 (541.4/385)		
	Spindle Type	-	BELT			
	Spindle Nose	-	A2-8			
	C-axis Indexing	deg	-	0.001°	-	0.001°
FEED	Travel (X/Z)	mm(in)	265/680 (10.4"/26.8")		265/830 (10.4"/32.7")	
	Rapid Traverse Rate (X/Z)	m/min (ipm)	24/30 (945/1,181)			
	Slide Type	-	BOX GUIDE			
TURRET	No. of Tools	ea	10 [12]	12	10 [12]	12
	Tool Size	OD	□ 25 (□ 1")			
		ID	mm(in)	Ø50 (Ø2")	Ø40 (Ø1.6")	Ø50 (Ø2")
	Indexing Time	sec	0.15			
LIVE TOOL	Motor (Max/Cont.)	kW(HP)	-	5.5/3.7 (7.4/5)	-	5.5/3.7 (7.4/5) [7.5/3.7 (10/5)]
	Milling Tool Speed (rpm)	r/min	-	6,000	-	5,000
	Torque (Max/Cont.)	N·m (lbfft)	-	52.5/26.5 (38.7/19.5)	-	70/35.4 (51.6/26.1) [95.5/35.4 (70.4/26.1)]
	Collet Size	mm(in)	-	Ø16 (0.6") - ER25	-	Ø25 (1") - ER32
	Type	-	-	BMT55P	-	BMT65P
TAIL STOCK	Taper	-	MT#5 [BUILT-IN TAIL STOCK : MT#4]			
	Quill Dia.	mm(in)	Ø100 (3.9)			
	Quill Travel	mm(in)	120 (4.7")			
	Travel	mm(in)	680 (26.8")		830 (32.7")	
TANK CAPACITY	Coolant Tank	ℓ(gal)	180 (47.6)		200 (52.8)	
	Lubricating Tank	ℓ(gal)	1.8 (0.5)			
POWER SUPPLY	Electric Power Supply	kVA	27			
	Thickness of Power Cable	Sq	Over 16			
	Voltage	V/Hz	220/60 (200/50)			
MACHINE	Floor Space (L×W)	mm(in)	3,400×1,708 (133.9"×37.2")		3,885×1,800 (153"×70.9")	
	Height	mm(in)	1,755 (69.1")		1,850 (72.8")	
	Weight	kg(lb)	5,800 (12,787)	5,850 (12,897)	5,950 (13,116)	6,000 (13,228)
PC	Controller	-	HYUNDAI WIA FANUC i Series - SMART PLUS			

Specifications are subject to change without notice for improvement.

# SPECIFICATIONS

## Specifications

[ ] : Option

MODEL		HD3100	HD3100L	HD3100M	HD3100LM	
CAPACITY	Swing Over the Bed	mm(in)	Ø750 (29.5")			
	Swing Over the Carriage	mm(in)	Ø500 (19.7")			
	Max. Turning Dia.	mm(in)	Ø500 (19.7")		Ø420 (16.5")	
	Max. Turning Length	mm(in)	780 (30.7")	1,300 (51.2")	740 (29.1")	1,260 (49.6")
	Bar Capacity	mm(in)	Ø102 (4")			
SPINDLE	Chuck Size	inch	12"			
	Spindle Bore	mm(in)	Ø115 (4.5")			
	Spindle Speed (rpm)	r/min	2,800 [2,800]		2,800	
	Motor (Max/Cont.)	kW(HP)	26/18.5 (35/25) [35/22 (47/29.5)]		26/18.5 (35/25)	
	Torque (Max/Cont.)	N·m (lbfft)	1,123/657 (828.7/484.6) [1,613/1,014 (1,189.7/747.9)]		1,123/657 (828.7/484.6)	
	Spindle Type	-	BELT [GEAR]		BELT	
	Spindle Nose	-	A2-11			
FEED	C-axis Indexing	deg	-		0.001°	
	Travel (X/Z)	mm(in)	265/830 (10.4"/32.7")	265/1,350 (10.4"/53.1")	265/830 (10.4"/32.7")	265/1,350 (10.4"/53.1")
	Rapid Traverse Rate (X/Z)	m/min (ipm)	24/30 (945/1,181)			
	Slide Type	-	BOX GUIDE			
TURRET	No. of Tools	ea	10 [12]		12	
	Tool Size	OD	mm(in)	□ 25 (□ 1")		
		ID	mm(in)	Ø50 (Ø2")		
	Indexing Time	sec	0.15			
LIVE TOOL	Motor (Max/Cont.)	kW(HP)	-		5.5/3.7 (7.4/5) [7.5/3.7 (10/5)]	
	Milling Tool Speed (rpm)	r/min	-		5,000	
	Torque (Max/Cont.)	N·m (lbfft)	-		70/35.4 (51.6/26.1) [95.5/35.4 (70.4/26.1)]	
	Collet Size	mm(in)	-		Ø25 (1") - ER32	
	Type	-	-		BMT65P	
TAIL STOCK	Taper	-	MT#5			
	Quill Dia.	mm(in)	Ø100 (3.9")			
	Quill Travel	mm(in)	120 (4.7")			
	Travel	mm(in)	830 (32.7")	1,350 (53.1")	830 (32.7")	1,350 (53.1")
TANK CAPACITY	Coolant Tank	ℓ(gal)	200 (52.8)	220 (58.1)	200 (52.8)	220 (58.1)
	Lubricating Tank	ℓ(gal)	1.8 (0.5)			
POWER SUPPLY	Electric Power Supply	kVA	Belt : 27 [Gear : 30]		27	
	Thickness of Power Cable	Sq	Over 16			
	Voltage	V/Hz	220/60 (200/50)			
MACHINE	Floor Space (L×W)	mm(in)	3,885×1,800 (153"×70.9")	4,405×1,978 (173.4"×77.9")	3,885×1,800 (153"×70.9")	4,405×1,978 (173.4"×77.9")
	Height	mm(in)	1,850 (72.8")			
	Weight	kg(lb)	6,000 (13,228)	7,200 (15,873)	6,050 (13,338)	7,250 (15,984)
PC	Controller	-	HYUNDAI WIA FANUC i Series - SMART PLUS			

\* Prior consultation is required when applying spindle contouring control for gear driven spindle.  
Specifications are subject to change without notice for improvement.

# CONTROLLER

## HYUNDAI WIA FANUC i Series – Smart Plus

[ ] : Option

Controlled axis / Display / Accuracy Compensation	
Control axes	2 axes (X, Z) / 3 axes (X, Z, C) / 4 axes (X,Z,Y,C) 5 axes (X, Z, B, C, A) / 6 axes (X, Z, Y, B, C, A) 7 axes (X1/Z1, X2/Z2, B2, C1/C2)
Simultaneously controlled axes	2 axes [Max. 4 axes]
Designation of spindle axes	3 axes [Max. 4 axes]
Least setting Unit	X, Z, Y, B axes : 0.001 mm (0.0001 inch) C, A axes : 0.001 deg
Least input increment	X, Z, Y, B axes : 0.001 mm (0.0001 inch) C, A axes : 0.001 deg
Inch / Metric conversion	G20 / G21
High response vector control	
Interlock	All axes / Each axis
Machine lock	All axes
Backlash compensation	± 0~9999 pulses (exc. Rapid traverse / Cutting feed)
Position switch	
LCD / MDI	15 inch LCD unit (with Touch Panel)
Feedback	Absolute motor feedback
Stored stroke check 1	Over travel
Stored stroke check 2, 3	
PMC axis control	
Operation	
Automatic operation (Memory)	
MDI operation	
DNC operation	Needed DNC software / CF card
Program restart	
Wrong operation prevention	
Program check function	Dry run
Single block	
Search function	Program Number / Sequence Number
Interpolation functions	
Nano interpolation	
Positioning	G00
Linear interpolation	G01
Circular interpolation	G02, G03
Exact stop mode	Single : G09, Continuous : G61
Dwell	G04, 0 ~ 9999.9999 sec
Skip	G31
Reference position return	1st reference : G28, 2nd reference : G30 Ref. position check : G27
Thread synchronous cutting	G33
Thread cutting retract	
Variable lead thread cutting	
Multi / Continuous threading	
Feed function / Acc. & Dec. control	
Manual feed	Rapid traverse Jog : 0~2,000 mm/min (79 ipm) Manual handle : x1, x10, x100 pulses Reference position return
Cutting Feed command	Direct input F code
Feedrate override	0 ~ 200% (10% Unit)
Rapid traverse override	1%, F25%, 50%, 100%
Override cancel	
Feed per minute	G98
Feed per revolution	G99
Look-ahead block	1 block
Program input	
Tape Code	EIA / ISO
Optional block skip	9 ea
Program stop / end	M00, M01 / M02, M30
Maximum command unit	± 999,999.999 mm (± 99,999.9999 inch)
Plane selection	X-Y : G17 / Z-X : G18 / Y-Z : G19
Workpiece coordinate system	G52, G53, 6 pairs (G54 ~ G59)
Manual absolute	Fixed ON
Programmable data input	G10
Sub program call	10 folds nested
Custom macro	#100 ~ #199, #500 ~ #999
G code system	A, B/C
Programmable mirror image	G51.1, G50.1
G code preventing buffering	G4.1
Direct drawing dimension program	Including Chamfering / Corner R
Conversational Program	SmartGuide-i

Program input	
Multiple repetitive cycles	I, II
Canned cycle for turning	
Auxiliary function / Spindle speed function	
Auxiliary function	M & 4 digit
Level-up M Code	High speed / Multi / Bypass M code
Spindle speed function	S & 5 digit, Binary output
Spindle override	0% ~ 150% (10% Unit)
Multi position spindle orientation	M19 (S##)
Rigid tapping	
Constant surface speed control	G96, G97
Tool function / Tool compensation	
Tool function	T & 2 digit + Offset 2 digit
Tool life management	
Tool offset pairs	128 pairs
Tool nose radius compensation	G40, G41, G42
Geometry / Wear compensation	
Direct input of offset measured B	
Editing function	
Part program storage size	5,120m (2MB)
No. of registerable programs	1,000 ea
Program protect	
Background editing	
Extended part program editing	Copy, move and change of NC program
Memory card program edit	
Data input / output & Interface	
I/O interface	CF card, USB memory Embedded Ethernet interface
Screen hard copy	
External message	
External key input	
External workpiece number search	
Automatic data backup	
Setting, display and diagnosis	
Self-diagnosis function	
History display & Operation	Alarm & Operator message & Operation
Run hour / Parts count display	
Maintenance information	
Actual cutting feedrate display	
Display of spindle speed / T code	
Graphic display	
Operating monitor screen	Spindle / Servo load etc.
Power consumption monitoring	Spindle & Servo
Spindle / Servo setting screen	
Multi language display	Support 24 languages
Display language switching	Selection of 5 optional Languages
LCD Screen Saver	Screen saver
Unexpected disturbance torque	BST (Back spin torque limit)
Function for machine type	
Cs contour control (C & A axes)	Mill, MS, Y, SY, LF-Mill, TTMS, TTSY
Polar coordinate interpolation	Mill, MS, Y, SY, LF-Mill, TTMS, TTSY
Cylindrical interpolation	Mill, MS, Y, SY, LF-Mill, TTMS, TTSY
Polygon turning (2 Spindles)	Mill, MS, Y, SY, LF-Mill, TTMS, TTSY
Canned cycle for drilling	Mill, MS, Y, SY, LF-Mill, TTMS, TTSY
Spindle orientation expansion	MS, SY, TTS, TTMS, TTSY
Spindle synchronous control	MS, SY, TTS, TTMS, TTSY
Torque control	MS, SY, TTS, TTMS, TTSY
Y axis offset	Y, SY, TTSY
Arbitrary angular control	Y, SY, TTSY
Composite / Superimposed control	MS, SY, TTS, TTMS, TTSY
Balance cutting	TTS, TTMS, TTSY
Option	
Fast ethernet	Needed option board
Data server	Needed option board
Protection of data at 8 levels	
Tool offset pairs	200 pairs
Helical interpolation	
Optional block skip	40 ea, 200 ea (AICC II)

Figures in inch are converted from metric values.

The FANUC controller specifications are subject to change based on the policy of company CNC supplying.



You Tube HYUNDAI WIA MT

[www.youtube.com/HYUNDAIWIAMT](http://www.youtube.com/HYUNDAIWIAMT)

## EXPERIENCE THE NEW TECHNOLOGY

With its top-quality HYUNDAI WIA machine tool creates a new and better world.



<http://machine.hyundai-wia.com>

HYUNDAI WIA Machine Tools  
Global Links

### HEADQUARTER

**Changwon Technical Center/R&D Center/Factory** 153, Jeongdong-ro, Seongsan-gu, Changwon-si, Gyeongsangnam-do, Korea TEL : +82 55 280 9114 FAX : +82 55 282 9114

**Overseas Sales Team /R&D Center** 37, Cheoldobangmulgwan-ro, Uiwang-si, Gyeonggi-do, Korea TEL : +82 31 8090 2539

### OVERSEAS OFFICES

**HYUNDAI WIA Machine America corp.** 450 Commerce Blvd, Carlstadt, NJ 07072, USA TEL : +1-201-987-7298

**HYUNDAI WIA Europe GmbH** Alexander-Fleming-Ring 57, 65428 Rüsselsheim Germany TEL : +49-0-6142-9256-0

**HYUNDAI WIA Machine Tools China** 2-3F, Bldg6, No.1535 Hongmei Road, Xuhui District, Shanghai, China TEL : +86-21-6427-9885

**India Branch Office** #4/169, 1st Floor, LOTTE BLDG, Rajiv Gandhi Salai, (OMR), Kandanchavadi, Chennai - 600096, Tamilnadu, India TEL : +91-76-0490-3348

**Vietnam Branch Office** Flat number 05, Service and Trade Center of Viet Huong Industrial Zone, Highway 13, Thuan Giao, Thuan An, Binh Duong, Vietnam TEL : +84-3-5399-5099

2021-07 002.006 ENG